

ENGINEERING MATERIAL

1.1 Introduction of Materials Science and Engineering

Materials Science – Investigating relationships that exist between the structure and properties of materials.

Materials Engineering – On the basis of these structure-property correlations, designing or engineering the structure of a material to produce a pre-determined set of properties.

Structure

Structure of a material usually relates to the arrangement of its internal components.

Subatomic - Structure involves electrons within the individual atoms and interactions with their nuclei.

Atomic level- structure encompasses the organization of atoms or molecules relative to one another.

Microscopic - Which contains large groups of atoms that are normally agglomerated together.

Macroscopic – viewable with the naked eye.

Property

A property is a material trait in terms of the kind and magnitude of response to a specific imposed stimulus. Properties are made independent of material shape and size.

Example-

A specimen subjected to forces will experience deformation,

A polished metal surface will reflect light.

Properties of solid materials may be grouped into six different categories: (1) mechanical, (2) electrical, (3) thermal, (4) magnetic, (5) optical and (6) deteriorative.



The four components of the discipline of materials science and engineering and their interrelationship.

Classification of Materials

Solid materials have been conveniently grouped into three basic classifications:

(1) metals, (2) ceramics, and (3) polymers.

1. Metals-

- Materials in this group are composed of one or more metallic elements (such as iron, aluminum, copper, titanium, gold, and nickel), and often also nonmetallic elements (for example, carbon, nitrogen, and oxygen) in relatively small amounts.
- Atoms in metals and their alloys are arranged in a very orderly manner.
- In comparison to the ceramics and polymers, are relatively dense.
- Mechanical Property- relatively stiff and strong, ductile (i.e., capable of large amounts of deformation without fracture), and are resistant to fracture.
- Metallic materials have large numbers of nonlocalized electrons; that is, these electrons are not bound to particular atoms. Many properties of metals are directly attributable to these electrons.
- Example, metals are extremely good conductors of electricity, and heat, and are not transparent to visible light; a polished metal surface has a lustrous appearance.
- Some of the metals (viz., Fe, Co, and Ni) have desirable magnetic properties.

2. Ceramics

- Ceramics are compounds between metallic and nonmetallic elements; they are most frequently oxides, nitrides, and carbides.
- Examples-aluminum oxide (or alumina, Al_2O_3), silicon dioxide (or *silica*, SiO_2), silicon carbide (SiC), silicon nitride (Si_3N_4).
- Examples of traditional ceramics — clay minerals (i.e., porcelain), cement, and glass.

Properties-

- Relatively stiff and strong—stiffnesses and strengths are comparable to those of the metals, very hard, extremely brittle (lack ductility), highly susceptible to fracture.
- Thermal and electrical Properties- Insulative to the passage of heat and electricity low electrical conductivities and are more resistant to high temperatures
- Optical characteristics-Ceramics may be transparent, translucent, or opaque.

Polymers

Carbon-based compounds

- Chain of H-C molecules. Each repeat unit of H-C is a monomer e.g. ethylene (C_2H_4), Polyethylene – ($-CH_2-CH_2-$)_n.
- Polymers include the familiar plastic and rubber materials.
- Many of them are organic compounds that are chemically based on carbon, hydrogen, and other nonmetallic elements (viz. O, N, and Si).
- They have very large molecular structures, often chain-like in nature that have a backbone of carbon atoms. Some of the common and familiar polymers are polyethylene (PE), nylon, poly (vinyl chloride)(PVC), polycarbonate (PC), polystyrene (PS), and silicone rubber.

Properties

- Low densities, not as stiff nor as strong as ceramics and metals.
- Extremely ductile and pliable (i.e., plastic).
- Relatively inert chemically and unreactive in a large number of environments.

Limitations

- Tendency to soften and/or decompose at modest temperatures, which, in some instances, limits their use.
- Low electrical conductivities and are nonmagnetic.

Composites

- A composite is composed of two (or more) individual materials, which come from the categories discussed above—viz., metals, ceramics, and polymers.
- Objective—to achieve a combination of properties that is not displayed by any single material

Examples

- Cemented carbides (WC with Co binder)
- Plastic molding compounds containing fillers
- Rubber mixed with carbon black
- Wood (a natural composite as distinguished from a synthesized composite)

Advance Materials

- Materials that are utilized in high-technology (or high-tech) applications are sometimes termed advanced materials.

Examples

- Include electronic equipment (camcorders, CD/DVD players, etc.), computers, fiber-optic systems, spacecraft, aircraft, and military rocketry, liquid crystal displays (LCDs), and fiber optics.
- These advanced materials may be typically traditional materials types (e.g., metals, ceramics, polymers) whose properties have been enhanced, and, also newly developed, high-performance materials.
- Advanced materials include semiconductors, biomaterials, and what we may term “materials of the future.”

Biomaterials

- Biomaterials are employed in components implanted into the human body for replacement of diseased or damaged body parts.
- These materials must not produce toxic substances and must be compatible with body tissues (i.e., must not cause adverse biological reactions).
- All of the above materials—metals, ceramics, polymers, composites, and semiconductors—may be used as biomaterials.

Example-

Titanium and its alloy, Co-Cr alloy, stainless steel, zirconia, HA, TiO₂ etc.

Semiconductors

- Semiconductors have electrical properties that are intermediate between the electrical conductors (viz. metals and metal alloys) and insulators (viz. ceramics and polymers).
- The electrical characteristics of these materials are extremely sensitive to the presence of minute concentrations of impurity atoms, for which the concentrations may be controlled over very small spatial regions.
- Semiconductors have made possible the advent of integrated circuitry that has totally revolutionized the electronics and computer industries (not to mention our lives) over the past three decades.

The Materials Selection Process

- Pick Application and determine required Properties.
- Properties: mechanical, electrical, thermal, magnetic, optical, deteriorative.
- Properties- Identify candidate Material(s)
- Material: structure, composition.
- Material- Identify required Processing
- Processing: changes structure and overall shape

Example: casting, sintering, vapor deposition, doping forming, joining, annealing.

1.2 Defects in Solids

- The term “*defect*” or “*imperfection*” is generally used to describe any deviation from the perfect periodic array of atoms in the crystal.
- The properties of some materials are extremely influenced by the presence of imperfections such as mechanical strength, ductility, crystal growth, magnetic hysteresis, dielectric strength, condition in semiconductors, which are termed structure sensitive are greatly affected by the-relatively minor changes in crystal structure caused by defects or imperfections.
- There are some properties of materials such as stiffness, density and electrical conductivity which are termed structure-insensitive, are not affected by the presence of defects in crystals.
- It is important to have knowledge about the types of imperfections that exist and the roles they play in affecting the behavior of materials.
- Crystal imperfections can be classified on the basis of their geometry as

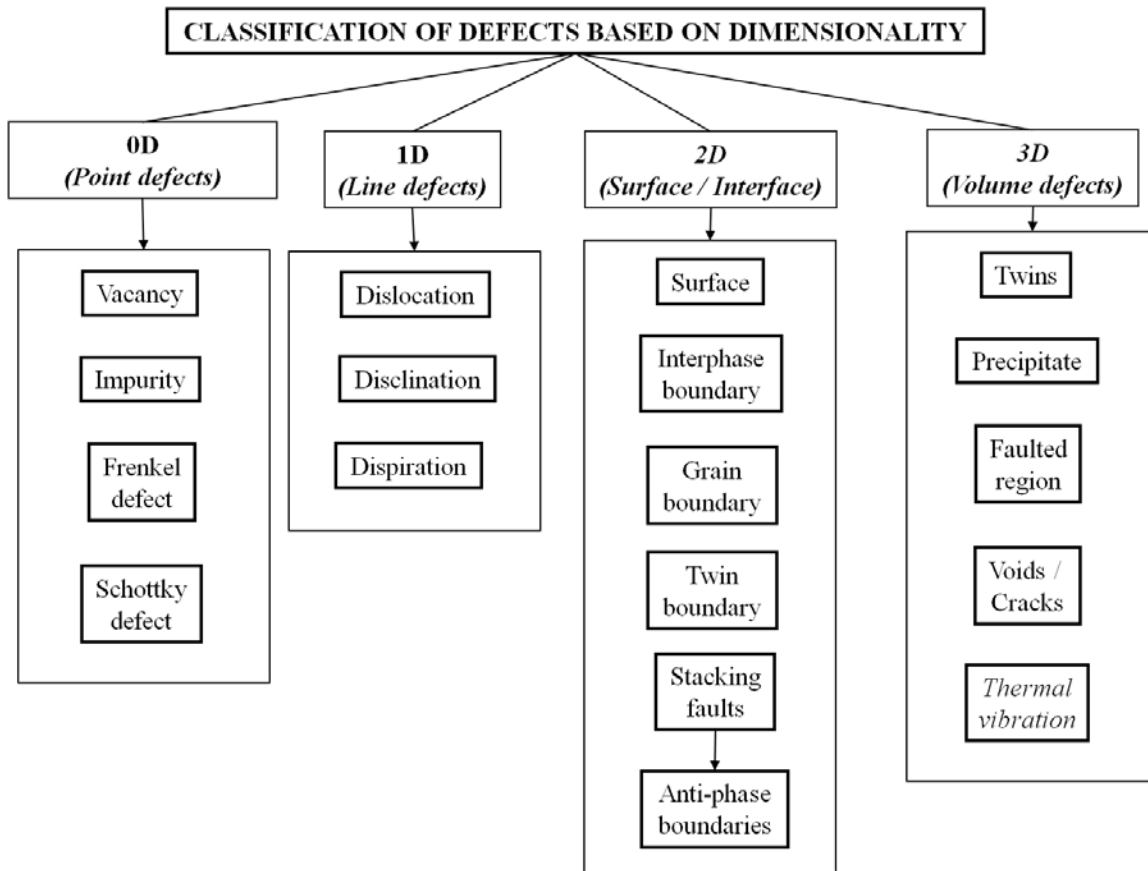

Point Defects in Metals

It is a zero dimension defect, associated with one or two atomic positions.

Vacancies -The simplest of the point defects is a **vacancy**, or vacant lattice site, one normally occupied from which an atom is missing. All crystalline solids contain vacancies and, in fact, it is not possible to create such a material that is free of these defects, vacant atomic sites in a structure.

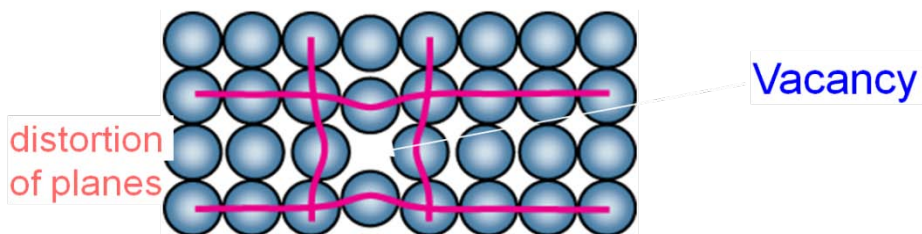

Self-Interstitials- when an atom occupies an interstitial site where no atom would ordinarily appear, causing an interstitialcy.

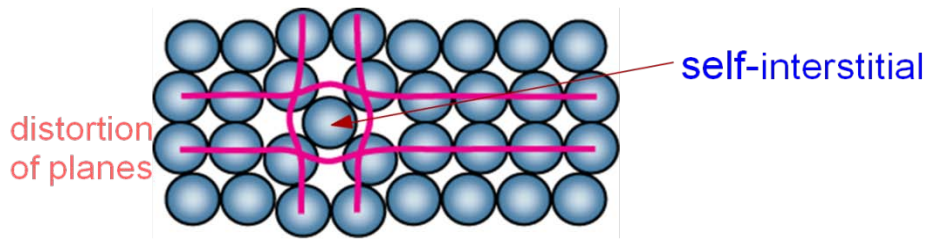

Point Defects in Ceramics

Vacancies- vacancies exist in ceramics for both cations and anions.

Interstitials - interstitials exist for cations, interstitials are not normally observed for anions because anions are large relative to the interstitial sites.

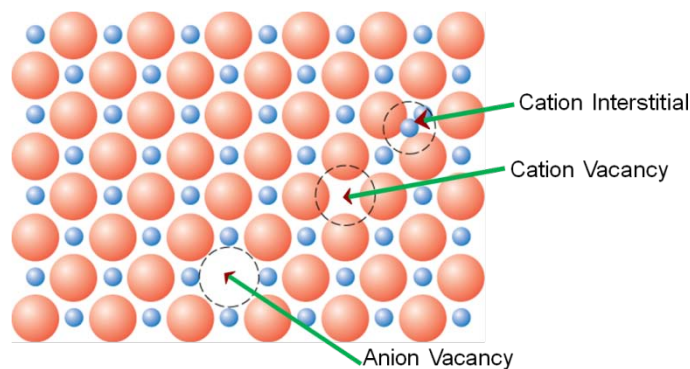

Frenkel Defect

To maintain the charge neutrality, a cation vacancy-cation interstitial pair occur together. This is called a **Frenkel defect**. The cation leaves its normal position and moves to the interstitial site. There is no change in charge because the cation maintains the same positive charge as an interstitial.

Schottky Defect

A cation vacancy–anion vacancy pair known as a **Schottky defect**. To maintain the charge neutrality, remove one cation and one anion; this creates two vacancies.

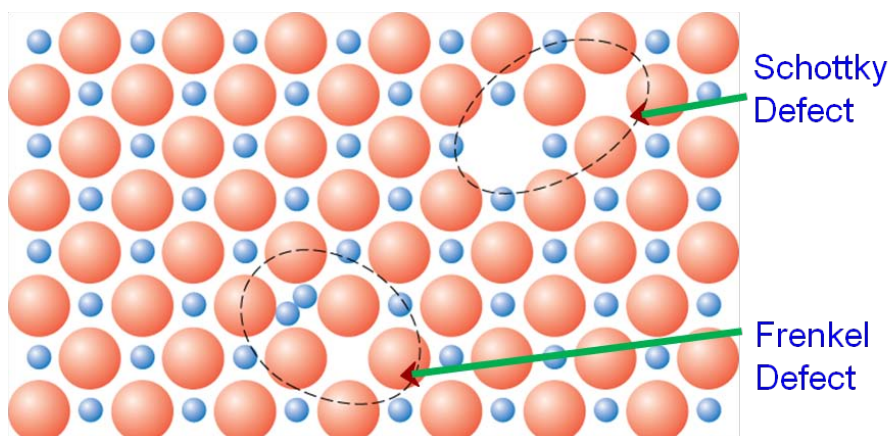

The equilibrium number of vacancies for a given quantity of material depends on and increases with temperature according to

$$N_v = N \exp\left(\frac{-Q_v}{KT}\right)$$

Equilibrium concentration varies with temperature

Where, N is the total number of atomic sites, Q_v is the energy required for the formation of a vacancy, T is the absolute temperature in kelvins, and k is the gas or Boltzmann's constant. 1.38×10^{-23} J/atom-K.

Equilibrium Concentration:

$$\frac{N_v}{N} = \exp\left(-\frac{\Delta H_f}{RT}\right)$$

1. Find the equilibrium concentration of vacancies in aluminium and nickel at 0K, 300 K and 900K. Given $\Delta H_f = 68 \times 10^3$ KJ/mol.

Solution-

(i) at 0K

$$\frac{N_v}{N} = \exp\left(-\frac{68 \times 10^3 \Delta H_f}{8.314 \times 0}\right) = \exp(-\infty) = 0$$

(ii) at 300 K

$$\frac{N_v}{N} = \exp\left(-\frac{68 \times 10^3 \Delta H_f}{8.314 \times 300}\right) = \exp(-27.26) = 1.45 \times 10^{-12}$$

2. Calculate the equilibrium number of vacancies per cubic meter for copper at 1000°C. The energy for vacancy formation is 0.9 eV/atom; the atomic weight and density (at 1000°C) for copper are 63.5 g/mol and 8.4 g/cm³, respectively.

Solution-

The value of N, the number of atomic sites per cubic meter for copper, from its atomic weight its density and Avogadro's number according to

$$N = \frac{N_A \rho}{A_{Cu}}$$

$$N = \frac{\left(6.023 \times \frac{10^{23} \text{ atoms}}{\text{mol}}\right) \times \left(8.4 \frac{\text{g}}{\text{cm}^3}\right) \times \left(10^6 \frac{\text{cm}^3}{\text{m}^3}\right)}{63.5 \text{ g/mol}}$$

$$= 8.0 \times 10^{28} \text{ atoms/m}^3$$

Thus, the number of vacancies at 1000°C (1273K) is equal to

$$N_v = \left(8.0 \times 10^{28} \frac{\text{atoms}}{\text{m}^3}\right) \exp\left(-\frac{0.9 \text{ eV}}{8.62 \times 10^{-5} \text{ eV/K} \times (1273\text{K})}\right)$$

$$= 2.2 \times 10^{25} \text{ vacancies/m}^3$$

EFFECT OF POINT IMPERFECTIONS

- The presence of a point imperfection introduces distortions in the crystal.
- In the case of impurity atom, because of its difference in size, elastic strains are created in the regions surrounding the impurity atom.
- All these factors tend to increase the potential energy of the crystal called '*enthalpy*'. The work done for the creation of such a point defect is called the '*enthalpy of formation*' of the point imperfection

LINE IMPERFECTIONS

- A *dislocation* is a linear or one-dimensional defect around which some of the atoms are misaligned. The defects, which take place due to distortion of atoms along a line, in some direction are called as '*line defects*'. Line defects are also called dislocations.
- It is responsible for the phenomenon of slip by which most metals deform plastically.

The two types of dislocations are,

Edge dislocation

- It is a linear defect that centers around the line that is defined along the end of the extra half-plane of atoms.
- The distorted configuration extends all along the edge into the crystal.
- Thus as the region of maximum distortion is centered around the edge of the incomplete plane, this distortion represents a line imperfection and is called an edge dislocation.
- Edge dislocations are represented by '⊥' or 'T' depending on whether the incomplete plane starts from the top or from the bottom of the crystal.
- These two configurations are referred to as positive and negative edge dislocations respectively.

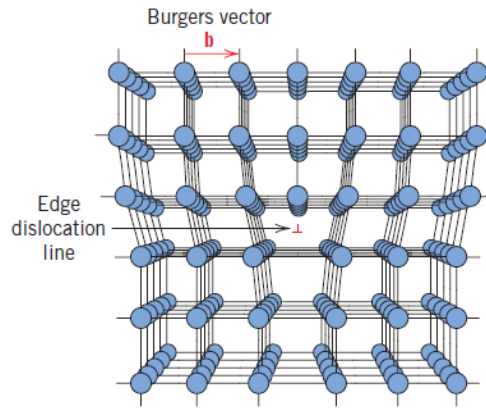

Screw dislocation:-

- In this dislocation, the atoms are displaced in two separate planes perpendicular to each other.
- It forms a spiral ramp around the dislocation.
- The Burgers Vector is parallel to the screw dislocation line.
- Speed of movement of a screw dislocation is lesser compared to edge dislocation.

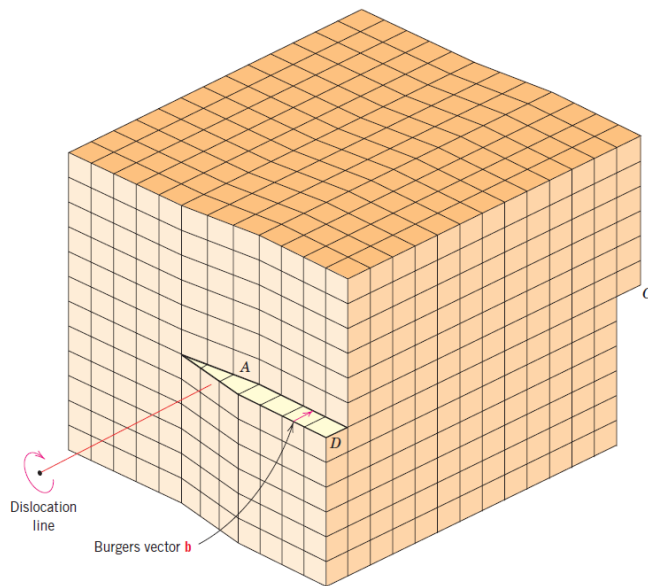

Burgers vector - The magnitude and direction of the lattice distortion associated with a dislocation is expressed in terms of a **Burgers vector**, denoted by a **b**.

The Burger vector can be found by the gap in the Burger circuit which is obtained by moving equal distances in each direction around the dislocation.

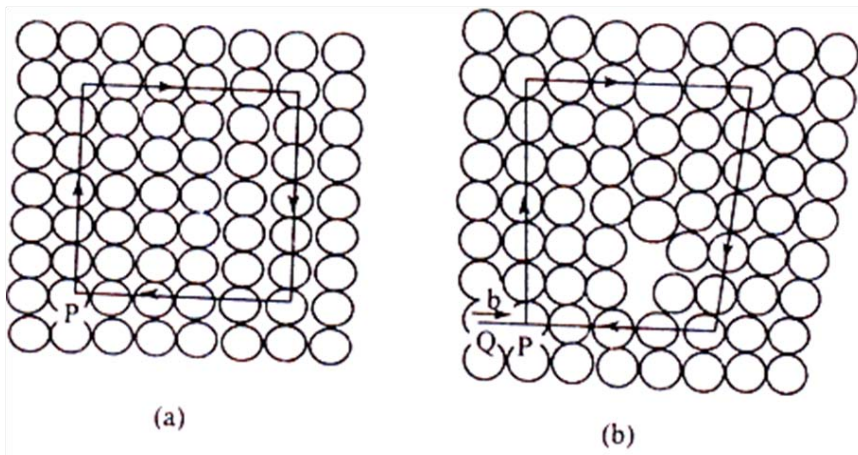

Mixed dislocations - Most dislocations found in crystalline materials are probably neither pure edge nor pure screw, but exhibit components of both types; these are termed mixed dislocations.

Surface imperfections

- Surface imperfections arise from a change in the stacking of atomic planes on or across a boundary.
- The change may be one of the orientations or of the stacking sequence of atomic planes.
- In geometric concept, surface imperfections are two-dimensional. They are of two types external and internal surface imperfections.

External Surfaces

- They are the imperfections represented by a boundary. At the boundary the atomic bonds are terminated.
- Surface atoms are not bonded to the maximum number of nearest neighbors, and are therefore in a higher energy state than the atoms at interior positions. The bonds of these surface atoms that are not satisfied give rise to a surface energy, expressed in units of energy per unit area (J/m^2 or erg/cm^2).

Grain Boundaries

- The boundary separating two small grains or crystals having different crystallographic orientations in polycrystalline materials.

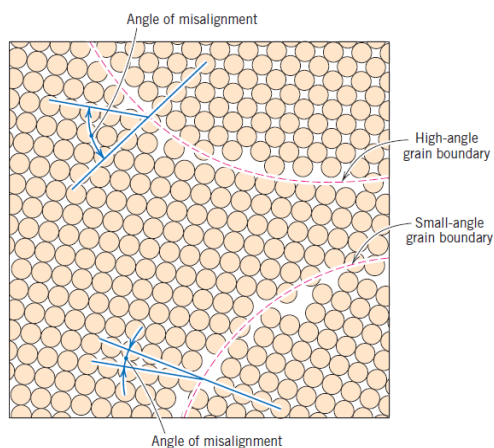

Twin Boundaries

- A *twin boundary* is a special type of grain boundary across which there is a specific mirror lattice symmetry; that is, atoms on one side of the boundary are located in mirror-image positions of the atoms on the other side.
- The region of material between these boundaries is appropriately termed a *twin*.
- Twins result from atomic displacements that are produced from applied mechanical shear forces (mechanical twins), and also during annealing heat treatments following deformation (annealing twins).

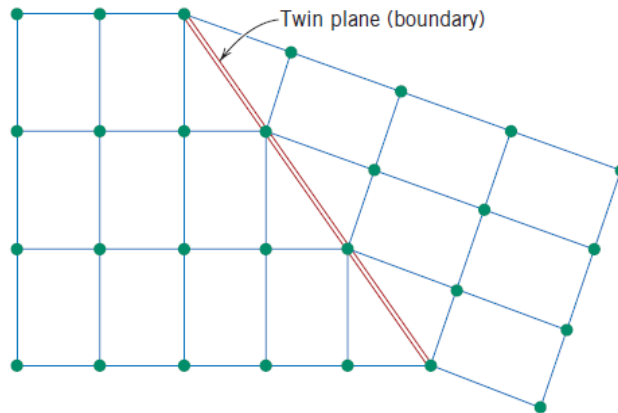

Volume Defects-

These include pores, cracks, foreign inclusions, and other phases. They are normally introduced during processing and fabrication steps.

Effect on property

- There are some properties of materials such as stiffness, density and electrical conductivity which are termed structure-insensitive, are not affected by the presence of defects in crystals while there are many properties of greatest technical importance such as mechanical strength, ductility, crystal growth, magnetic.
- Hysteresis, dielectric strength, condition in semiconductors, which are termed structure sensitive are greatly affected by the-relatively minor changes in crystal structure caused by defects or imperfections.

1.3 Diffusion in solids

Diffusion is a process of mass transport by atomic movement under the influence of thermal energy and a concentration gradient. Atoms move from higher to lower concentration region.

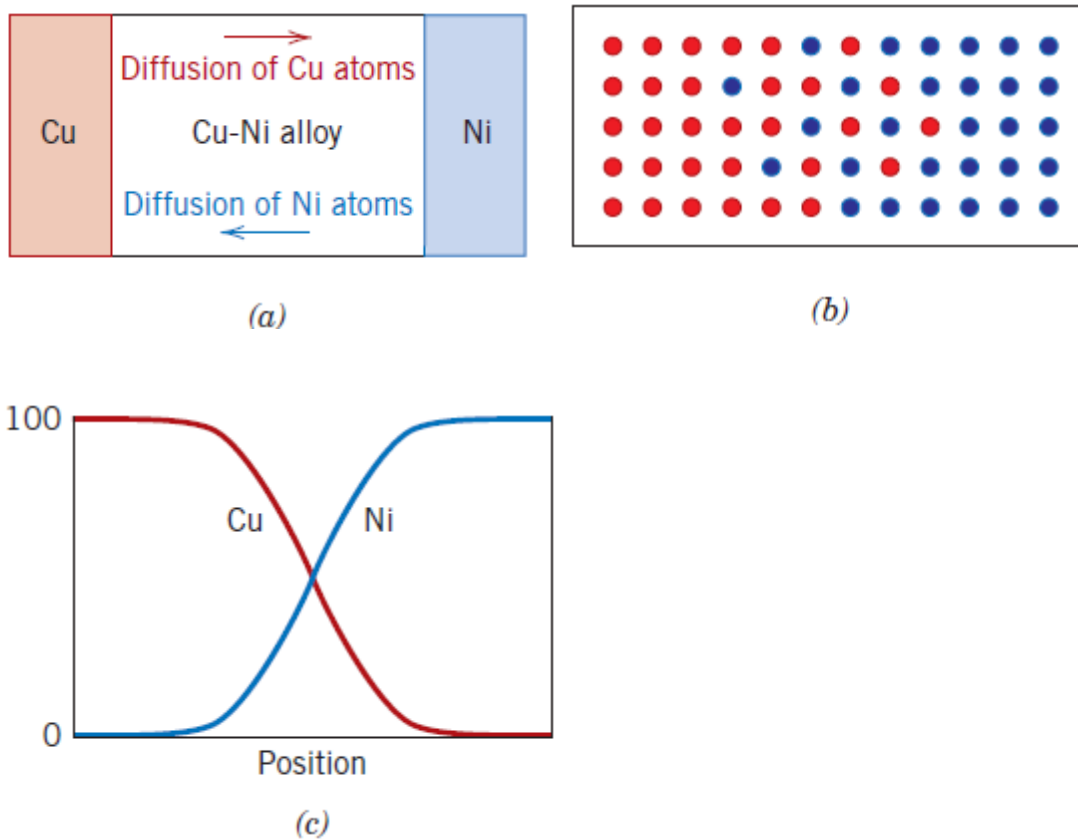

Figure 1. (a) A copper–nickel diffusion couple after a high-temperature heat treatment, showing the alloyed diffusion zone. (b) Schematic representations of Cu (red circles) and Ni (blue circles) atom locations within the couple. (c) Concentrations of copper and nickel as a function of position across the couple.

Figure 1 shows, pure copper and nickel at the two extremities of the couple, separated by an alloyed region. Concentrations of both metals vary with position as shown in Figure 1(c). This result indicates that copper atoms have migrated or diffused into the nickel, and that nickel has diffused into copper.

Diffusion Mechanisms

Diffusion is just the stepwise migration of atoms from lattice site to lattice site. In fact, the atoms in solid materials are in constant motion. For an atom to make such a move, two conditions must be met: (1) there must be an empty adjacent site, and (2) the atom must have sufficient energy to break bonds with its neighbor atoms and then cause some lattice distortion during the displacement.

Vacancy Diffusion

In this mechanism involves the interchange of an atom from a normal lattice position to an adjacent vacant lattice site or vacancy. This process necessitates the presence of vacancies, and the extent to which vacancy diffusion can occur is a function of the number of these defects that are present. Diffusing atoms and vacancies exchange positions, the diffusion of atoms in one direction corresponds to the motion of vacancies in the opposite direction. Both self-diffusion and inter-diffusion occur by this mechanism.

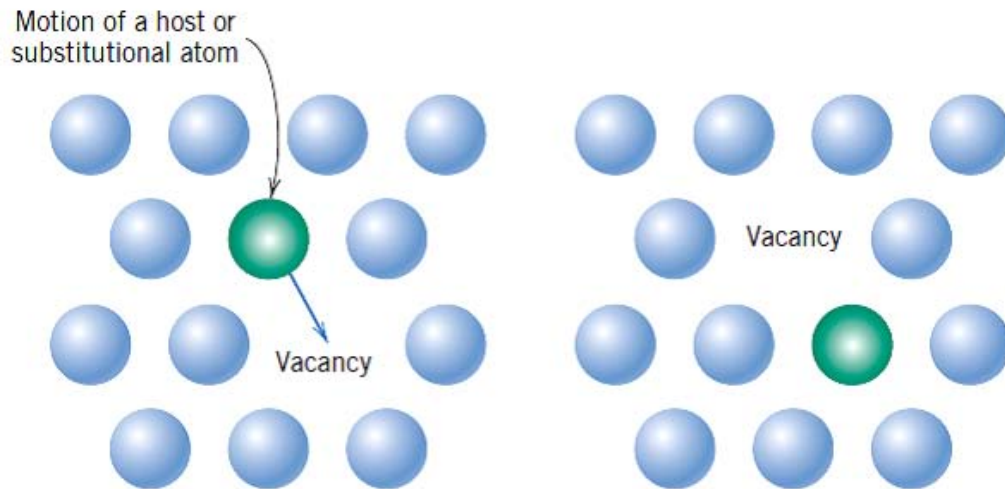

Interstitial Diffusion

In this diffusion involves atoms that migrate from an interstitial position to a neighboring one that is empty. This mechanism is found for inter-diffusion of impurities such as hydrogen, carbon, nitrogen, and oxygen, which have atoms that are small enough to fit into the interstitial positions. In most metal alloys, interstitial diffusion occurs much more rapidly than diffusion by the vacancy mode, since the interstitial atoms are smaller and thus more mobile.

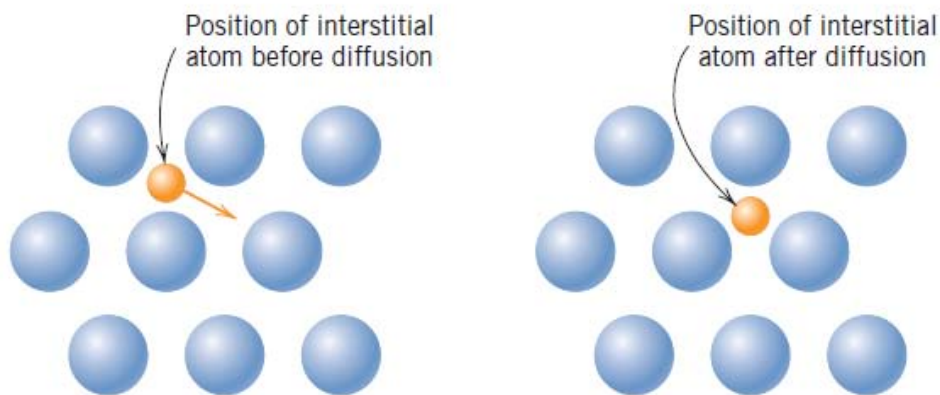

Steady-state diffusion

Steady-state diffusion is the situation when the diffusion flux is independent of time. Fick's first law describes steady-state diffusion and is given by

$$J = -D \frac{dC}{dx}$$

Where, J is the diffusion flux or the mass transported per unit time per unit area and dC/dx is the concentration gradient. D is known as the diffusion coefficient

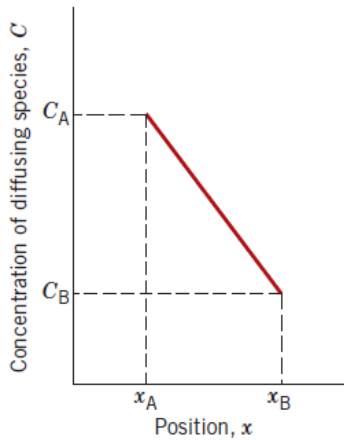

The negative sign in this expression indicates that the direction of diffusion is down the concentration gradient, from a high to a low concentration

Example-

Diffusion of atoms of a gas through a plate of metal for which the concentrations (or pressures) of the diffusing species on both surfaces of the plate are held constant.

Non-steady-state diffusion

Most practical diffusion situations are non steady-state ones. In this the diffusion flux and the concentration gradient at some particular point in a solid vary with time, with a net accumulation or depletion of the diffusing species resulting.

This is described by Fick's second law

$$\frac{\partial C}{\partial t} = \frac{\partial}{\partial x} \left(D \frac{\partial C}{\partial x} \right) \dots \dots (1)$$

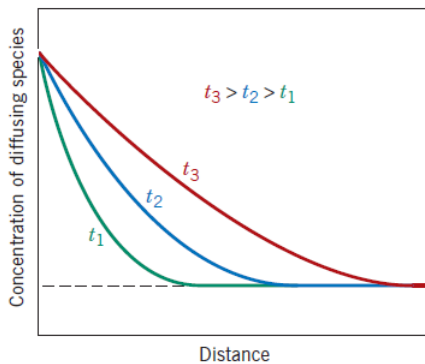

A solution to this equation can be obtained for a semi-infinite solid with the following boundary conditions

For $t=0$, $C = C_0$ at $0 \leq x \leq \infty$

For $t > 0$, $C = C_s$ at $x=0$

$C=C_0$ at $x=\infty$

Application of these boundary conditions to Equation 1 yields the solution

$$\frac{C_x - C_0}{C_s - C_0} = 1 - \text{erf} \left(\frac{x}{2\sqrt{Dt}} \right)$$

Factors affecting Diffusion

Diffusing species

The magnitude of the diffusion coefficient D is indicative of the rate at which atoms diffuse. Coefficients, both self- and inter-diffusion. The diffusing species as well as the host material influence the diffusion coefficient. As the value of D is fixed for a given element in a given material, the extent of diffusion is first decided by the diffusing species itself.

Temperature

Temperature is the most important factor, which influence on the coefficients and diffusion rates. Temperature dependence of the diffusion coefficient is expressed as

$$D = D_0 \exp\left(-\frac{Q_d}{RT}\right)$$

Where, D_0 is the pre-exponential factor, Q_d is the activation energy for diffusion, T is absolute temperature in kelvin and R is gas constant.

Mechanisms/modes of plastic deformation

Plastic deformation in crystalline solid is accomplished by means of various processes mentioned below; among which slip is the most important mechanism.

Plastic deformation of crystalline materials takes place by mechanisms which are very different from that for amorphous materials (glasses). Plastic deformation in amorphous materials occur by other mechanisms including flow (~viscous fluid) and shear banding.

Plastic deformation by dislocation Motion (SLIP)

- SLIP is the most important mechanism of plastic deformation. At low temperatures (especially in BCC metals) twinning may also become important.
- At the fundamental level plastic deformation (in crystalline materials) by slip involves the motion of dislocations on the slip plane (*creating a step of Burgers vector*).
- Slip is caused by shear stresses (at the level of the slip plane). Hence, a purely hydrostatic state of stress cannot cause slip.
- A slip system consists of a slip direction lying on a slip plane.
- Slip is analogous to the mode of locomotion employed by a caterpillar

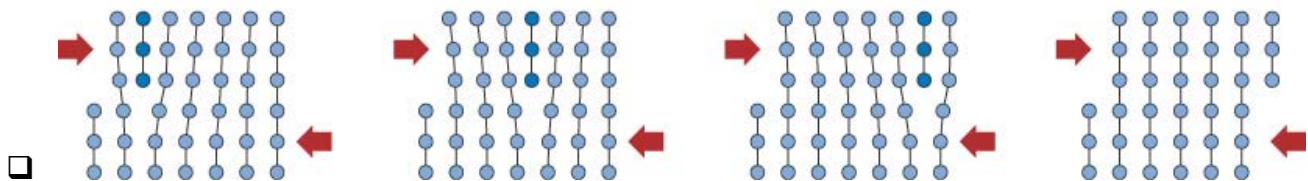

- Dislocations move more easily on specific planes and in specific directions.
- Ordinarily, there is a preferred plane (slip plane), and specific directions (slip direction) along which dislocations move. The combination of slip plane and slip direction is called the slip system.
- The slip system depends on the crystal structure of the metal.
- The slip plane is the plane that has the most dense atomic packing (the greatest planar density). The slip direction is most closely packed with atoms (highest linear density).
- In CCP, HCP materials the slip system consists of a close packed direction on a close packed plane.
- Just the existence of a slip system does not guarantee slip → slip is competing against other processes like twinning and fracture. If the stress to cause slip is very high (i.e. CRSS is very high), then fracture may occur before slip (like in brittle ceramics).

- ❑ For slip to occur in polycrystalline materials, 5 independent slip systems are required. Hence, materials which are ductile in single crystalline form may not be ductile in polycrystalline form. CCP crystals (Cu, Al, and Au) have excellent ductility.
- ❑ At higher temperatures more slip systems may become active and hence polycrystalline materials which are brittle at low temperature may become ductile at high temperature.

Crystal	Slip plane(s)	Slip direction	Number of slip systems
FCC	{111}	$\frac{1}{2}\langle 110 \rangle$	12
HCP	(0001)	$\langle 11 \bar{2}0 \rangle$	3
BCC	{110}, {112}, {123}	$\frac{1}{2}[111]$	48
NaCl (<i>Ionic</i>)	{110} {111} not a slip plane	$\frac{1}{2}\langle 110 \rangle$	6
C (<i>Diamond cubic</i>)	{111}	$\frac{1}{2}\langle 110 \rangle$	12
TiO ₂ (<i>Rutile</i>)	{101}	$\langle 10 \bar{1} \rangle$	
CaF ₂ , UO ₂ , ThO ₂ <i>Fluorite</i>	{001}	$\langle 1 \bar{1}0 \rangle$	
CsCl	{110}	$\langle 001 \rangle$	
NaCl, LiF, MgO <i>Rock Salt</i>	{110}	$\langle 110 \rangle$	6
C, Ge, Si <i>Diamond cubic</i>	{111}	$\langle 110 \rangle$	12
MgAl ₂ O ₄ <i>Spinel</i>	{111}	$\langle 1 \bar{1}0 \rangle$	
Al ₂ O ₃ <i>Hexagonal</i>	(0001)	$\langle 11 \bar{2}0 \rangle$	

Slip in Single Crystal

- If a single crystal of a metal is stressed in tension beyond its elastic limit, it elongates slightly and a step appears on the surface due to the relative displacement of one part of the crystal with respect to the others and the elongation stops.

- Further increase in the load causes movement of another parallel plane, resulting in another step. Similarly numbers of small steps are formed on the surface of the single crystal that are parallel to one another and loop around the circumference of the specimen.
- Each step (shear band) results from the movement of a large number of dislocations and their propagation in the slip system.

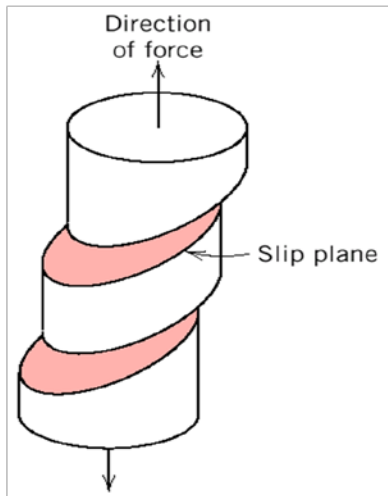

Macroscopic slip in single crystal

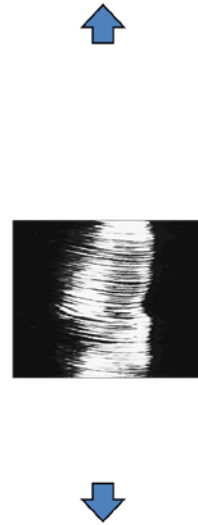

Slip in a zinc single crystal

- Extent of slip in a single crystal depends on the magnitude of shearing stress produced by external loads, geometry of the crystal structure and the orientation of the active slip planes with respect to the shearing stress.
- Slip begins when the shearing stress on slip plane in the slip direction/Resolved Shear Stress (RSS) reaches a critical value called the Critical Resolved Shear Stress (CRSS) and plastic deformation starts (*The actual Schmid's law*)
- Even if we apply a tensile force on the specimen → the shear stress resolved onto the slip plane is responsible for slip.

$$\text{Stress} = \left(\frac{\text{Force}}{\text{Area}} \right)_{1D}$$

$$\tau = \left(\frac{F \cos \alpha}{A / \cos \theta} \right)$$

$$\tau_{RSS} = \sigma \cos \theta \cos \phi$$

Schmid factor

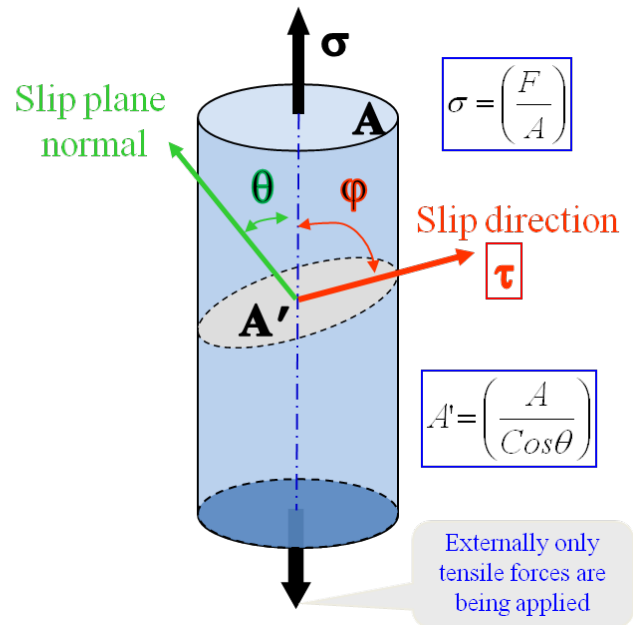

- τ_{RSS} is maximum ($P/2A$) when $\phi = \lambda = 45^\circ$
- If the tension axis is normal to slip plane i.e. $\lambda = 90^\circ$ or if it is parallel to the slip plane i.e. $\phi = 90^\circ$ then $\tau_{RSS} = 0$ and slip will not occur as per Schmid's law.

Schmid's law

Slip is initiated when

$$\tau_{RSS} \geq \tau_{CRSS}$$

- τ_{CRSS} is a material parameter, which is determined from experiments.

Yield strength of a single crystal

$$\sigma_y = \frac{\tau_{CRSS}}{\cos \theta \cos \phi}$$

Problem

Consider a single crystal of BCC iron oriented such that a tensile stress is applied along a [010] direction.

- Compute the resolved shear stress along a (110) plane and in a [111] direction when a tensile stress of 52 MPa (7500 psi) is applied
- If slip occurs on a (110) plane and in a $\bar{[111]}$ direction, and the critical resolved shear stress is 30 MPa (4350 psi), calculate the magnitude of the applied tensile stress necessary to initiate yielding.

Solution

Determine the value of θ , the angle between the normal to the (110) slip plane (i.e., the [110] direction) and the [010] direction using $[u_1v_1w_1] = [110]$, $[u_2v_2w_2] = [010]$ and the following equation.

$$\theta = \cos^{-1} \left(\frac{u_1u_2 + v_1v_2 + w_1w_2}{\sqrt{(u_1^2 + v_1^2 + w_1^2)(u_2^2 + v_2^2 + w_2^2)}} \right)$$

$$\phi = \cos^{-1} \left(\frac{(1)(0) + (1)(1) + (0)(0)}{\sqrt{[(1)^2 + (1)^2 + (0)^2][(0)^2 + (1)^2 + (0)^2]}} \right)$$

$$= \cos^{-1} \left(\frac{1}{\sqrt{2}} \right) = 45^\circ$$

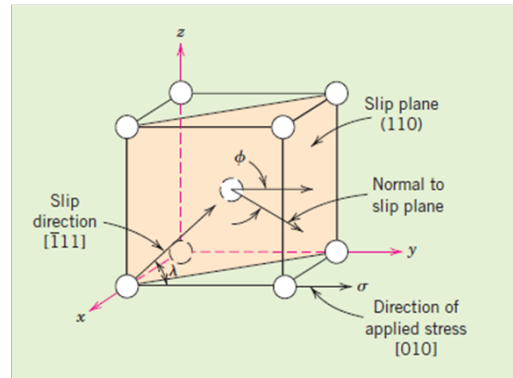

- Similarly determine the value of λ , the angle between $[\bar{1}11]$ and [010] directions as follows:

$$\lambda = \cos^{-1} \left(\frac{(-1)(0) + (1)(1) + (1)(0)}{\sqrt{[(-1)^2 + (1)^2 + (1)^2][(0)^2 + (1)^2 + (0)^2]}} \right) = \cos^{-1} \left(\frac{1}{\sqrt{3}} \right) = 54.7^\circ$$

- Then calculate the value of τ_{RSS} using the following expression

$$\begin{aligned} \tau_{RSS} &= \sigma \cos \phi \cos \lambda \\ &= (152 \text{ Mpa})(\cos 45)(\cos 54.7) \\ &= 21.3 \text{ Mpa} \\ &= 13060 \text{ psi} \end{aligned}$$

- Yield Strength σ_y

$$\sigma_y = \frac{30 \text{ Mpa}}{(\cos 45)(\cos 54.7)} = 73.4 \text{ Mpa}$$

Plastic deformation by Twin

- In addition to slip (dislocation movement), plastic deformation can also occur by twinning.

- Twinning results when a portion of the crystal takes up an orientation that is related to the orientation of the rest of the un twinned lattice in a definite, symmetrical way.
- Twinned portion of the crystal is a mirror image of the parent crystal and the plane of symmetry between the two portions is called twinning plane.
- Twinning may favorably reorient slip systems to promote dislocation movement.

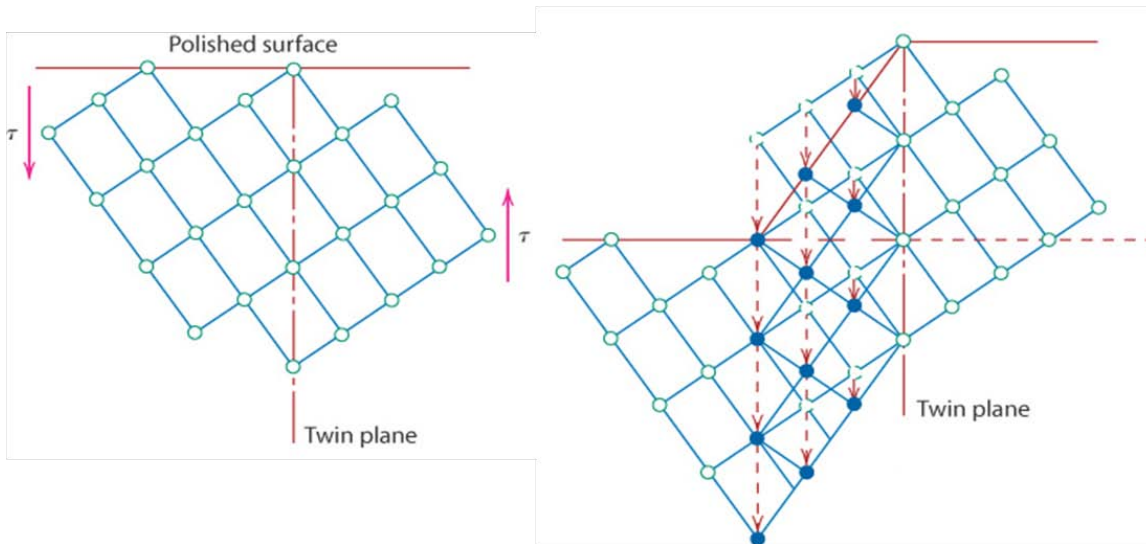

- Twins are generally of two types: Mechanical Twins and Annealing twins
- Mechanical twins are generally seen in bcc or hcp metals and produced under conditions of rapid rate of loading and decreased temperature.
- Annealing twins are produced as the result of annealing. These twins are generally seen in fcc metals.
- Annealing twins are usually broader and with straighter sides than mechanical twins.

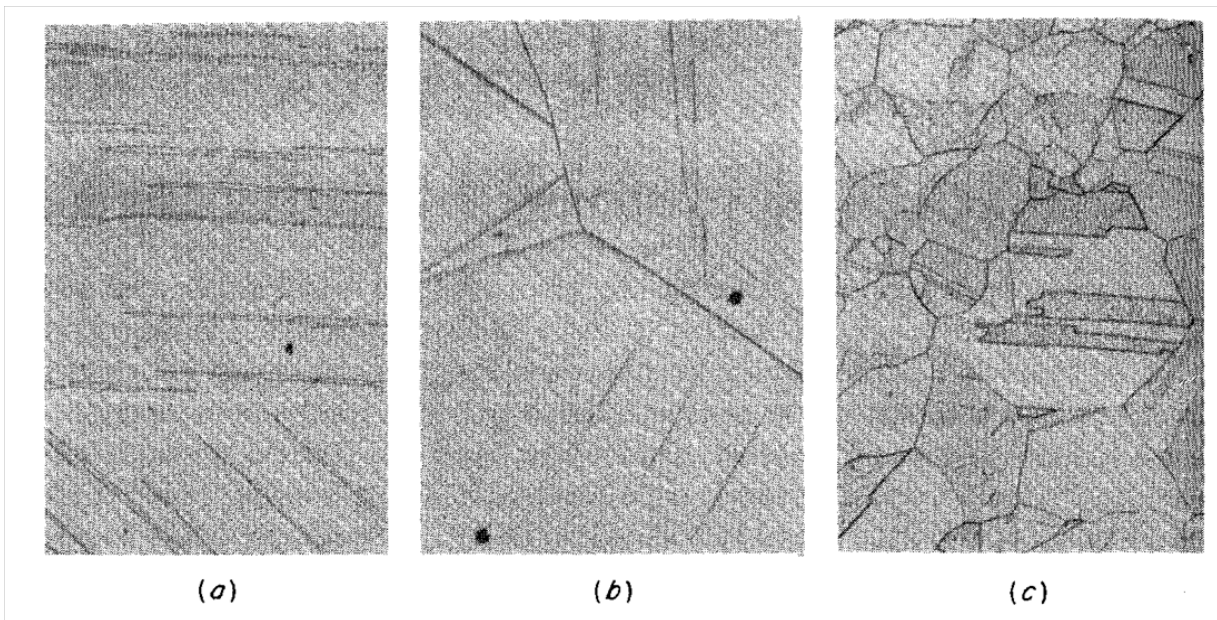

(a) Mechanical Twins (Neumann bands in iron), (b) Mechanical Twins in zinc produced by polishing (c) Annealing Twins in gold-silver alloy

- Twinning generally occurs when the slip systems are restricted or when the slip systems are restricted or when something increases the critical resolved shear stress so that the twinning stress is lower than the stress for slip.
- So, twinning generally occurs at low temperatures or high strain rates in bcc or fcc metals or in hcp metals.
- Twinning occurs on specific twinning planes and twinning directions.

Crystal Structure	Typical Examples	Twin Pl
BCC	α -Fe, Ta	(112
HCP	Zn, Cd, Mg, Ti	
FCC	Ag, Au, Cu	(111

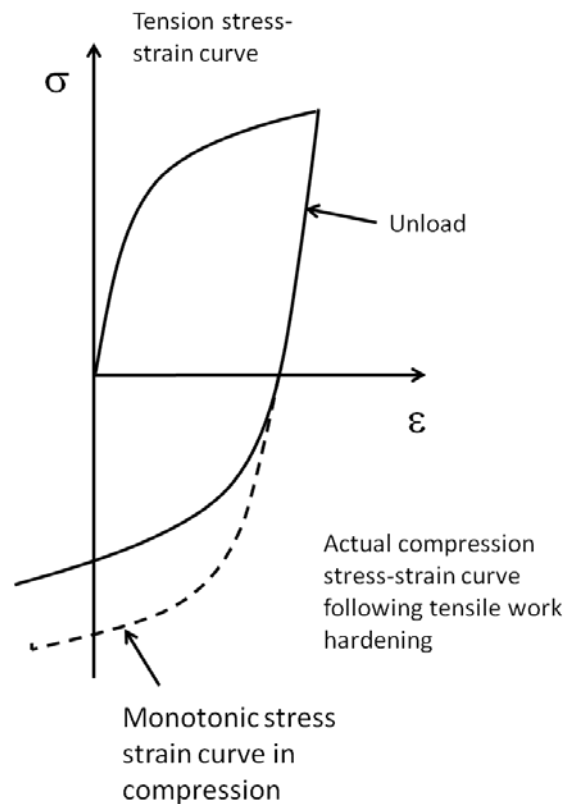

Bauschinger effect

- The **Bauschinger effect** refers to a property of materials where the material's stress/strain characteristics change as a result of the microscopic stress distribution of the material. For example, an increase in tensile yield strength occurs at the expense of compressive yield strength. The effect is named after German engineer Johann Bauschinger.
- The Bauschinger effect is normally associated with conditions where the yield strength of a metal decreases when the direction of strain is changed. It is a general phenomenon found in most polycrystalline metals.
- The basic mechanism for the Bauschinger effect is related to the dislocation structure in the cold worked metal. As deformation occurs, the dislocations will accumulate at barriers and produce dislocation pile-ups and tangles. Based on the cold work structure, two types of mechanisms are generally used to explain the Bauschinger effect.

Work Hardening

Room temperature deformation.

- Common forming techniques used to change the cross sectional area:

-Forging

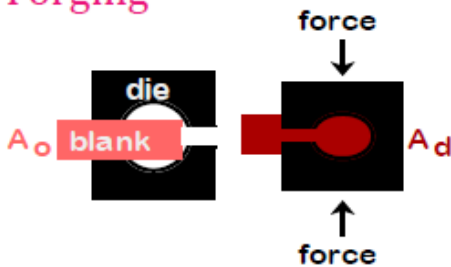

-Rolling

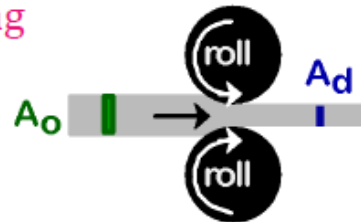

-Drawing

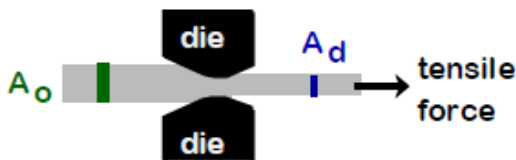

-Extrusion

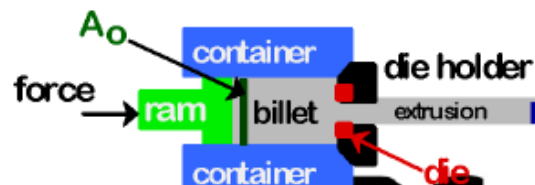

$$\%CW = \frac{A_o - A_d}{A_o} \times 100$$

Dislocations during Cold Work

- Dislocations entangle one another during cold work.
- Dislocation motion becomes more difficult, which makes the material stronger overall

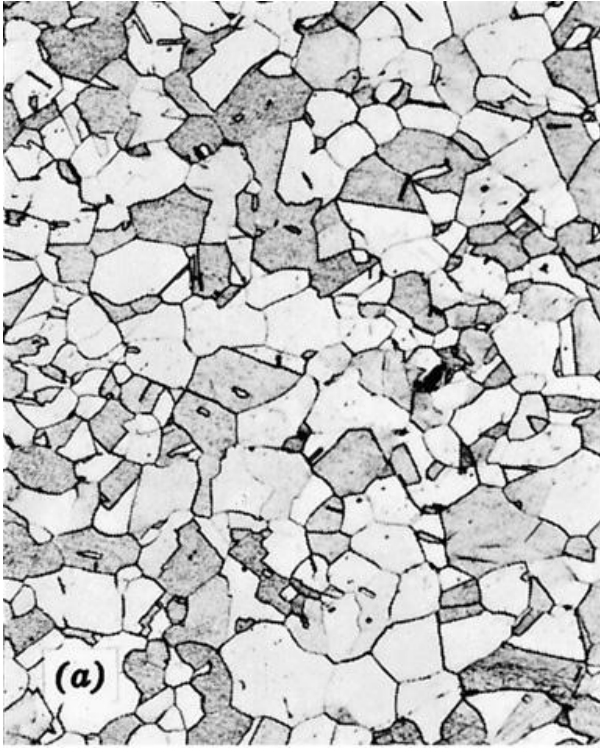

Isotropic grains are approx. spherical, equiaxed & randomly oriented.



Anisotropic (directional) since rolling affects grain orientation and shape.

Result of Cold Work

- Dislocation density increases, which leads to an increase in yield strength: Materials become harder.
- Ductility and tensile strength also increase.

Recovery, Recrystallization & Grain Growth

Recovery

- Recovery takes place at low temperatures of annealing.
- Apparently no change in microstructure.
- During recovery, some of the stored internal strain energy is relieved through dislocation motion due to enhanced atomic diffusion at the elevated temperatures.

- Leads to reduction in the number of dislocations.
- This process also removes the residual stresses formed due to cold working significant.
- The recovering of physical and mechanical properties varies with the temperature and time.
- Recovery is a relaxation process with the following characteristics:
 - There is no incubation period
 - Recovery rate is large at the beginning, and then it slows down till it is near zero
 - Recovery has a limit value varying with temperature; the higher the temperature, the greater is the limit value and the shorter is the time needed to reach the limit value
 - The greater the deformation, the greater is the initial recovery rate, and decrease in grain size helps to accelerate the recovery process

The characteristic of recovery can be expressed as the following equation:

$$\frac{dx}{dt} = -cx$$

Where

t is the time of heating under constant temperature

x is the fraction of property increase caused by cold work after heating

c is a constant related with material and temperature

The value of constant parameter c can be described with the Arrhenius equation:

$$c = c_0 \exp\left(\frac{-Q}{RT}\right)$$

Recrystallization

- After recovery is complete, the grains are still in a relatively high strain energy state.
- Recrystallization is the formation of a new set of strain-free and uniaxial grains that have low dislocation densities.
- The temperature at which materials are recrystallized is known as the recrystallization temperature, $T_{\text{recrystallization}} \in (0.3 - 0.5) T_m$
- The driving force to produce the new grain structure is the internal energy difference between strained and unstrained material.
- •The new grains form as very small nuclei and grow until they consume the parent material.
- Recrystallization is a heterogeneous process and dependent on the deformation state of steels.
- The kinetics of recrystallization depends on nucleation rate, N, and growth rate, G.

Grain Growth

- After recrystallization, the strain-free grains will continue to grow if the metal specimen is left at elevated temperatures. Grains begin to grow via grain boundary immigration; this phenomenon is called grain growth.

- Grain growth is driven by the tendency to decrease the total boundary surface energy by decreasing the grain boundary area.
- Large grains grow at the expense of smaller grains.

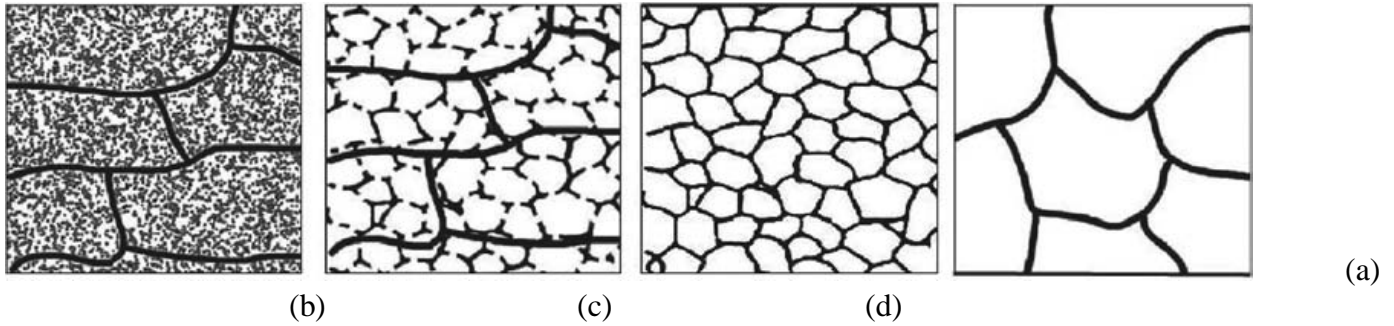
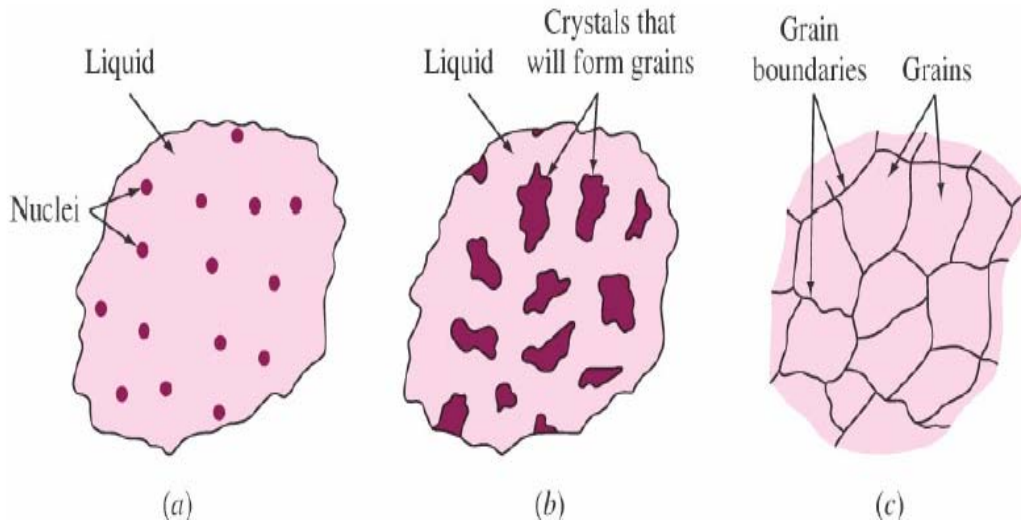

Fig.1.1. (a) Work hardening, (b) recovery, (c) recrystallization, and (d) grain growth during annealing.

1. Callister's Materials Science and Engineering William D Callister (Adapted by R. Balasubramaniam) Wiley Inida (P) Ltd., 2007.

Solidification

Solidification is basically phase transformation from liquid phase to solid phase. The progress of a phase transformation takes place in two stages: **nucleation** and **growth**. Nucleation involves the appearance of very small particles, or nuclei of the new phase (often consisting of only a few hundred atoms), which are capable of growing. During the growth stage these nuclei increase in size, which results in the disappearance of some (or all) of the parent phase.



Cooling Curve

Driving Force

Solidification is undoubtedly the most important processing route for metals and alloys. Consider a pure metal (Fig. 1). At the fusion temperature T_f , $\Delta G = 0$ so that

$$\Delta G_f = \Delta H_f - T_f \Delta S_f = 0 \text{ or } \Delta H_f = T_f \Delta S_f$$

where ΔH_f is the latent heat of fusion, ΔG_f is the Gibb's and ΔS_f is the entropy, i.e. positive for melting. For any T ,

$$\Delta G = \Delta H - T \Delta S$$

$$\text{Or } \Delta G \cong \Delta H_f - T \Delta S_f$$

$$= \Delta S_f (T_f - T) = \Delta S_f \Delta T$$

Where ΔT is undercooling.

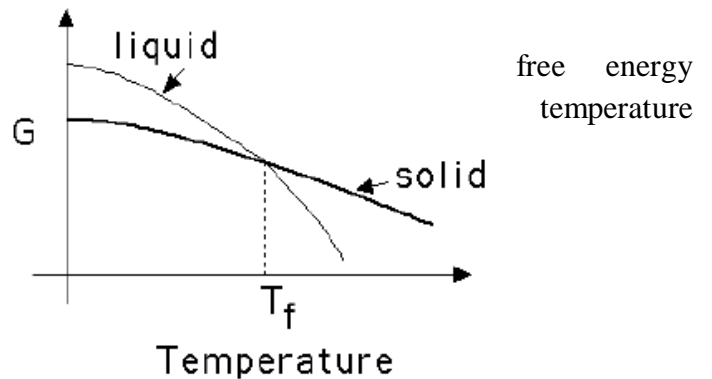

Fig.1 Driving Force for nucleation.

The driving force is therefore proportional to the undercooling provided that the latent heat and the entropy of fusion do not vary much with temperature.

Nucleation

There are two types of nucleation: *homogeneous* and *heterogeneous*. The distinction between them is made according to the site at which nucleating events occur. For the homogeneous type, nuclei of the new phase form uniformly throughout the parent phase, whereas for the heterogeneous type, nuclei form preferentially at structural inhomogeneities, such as container surfaces, insoluble impurities, grain boundaries, dislocations, and so on.

Homogeneous Nucleation

Nucleation without preferential nucleation sites is homogeneous nucleation. Homogeneous nucleation occurs spontaneously and randomly, but it requires Superheating or supercooling of the medium.

Let us first consider the solidification of a pure material, assuming that nuclei of the solid phase form in the interior of the liquid as atoms cluster together so as to form a packing arrangement similar to that found in the solid phase. Furthermore, it will be assumed that each nucleus is spherical in geometry and has a radius r .

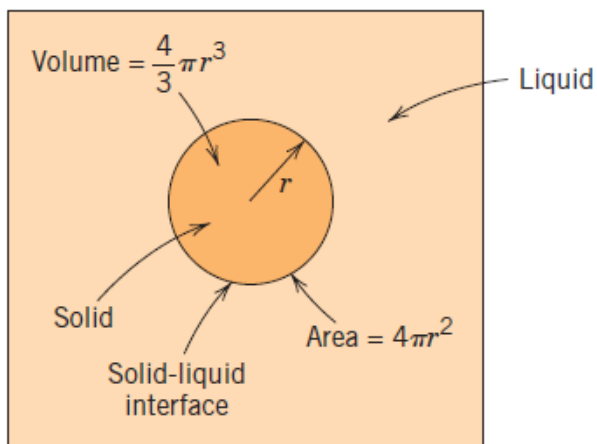

Fig.2 Schematic diagram showing the

There are two contributions to the total free energy change that accompany a solidification transformation.

(i) The first is the free energy difference between the solid and liquid phases, or the volume free energy, i.e. $\frac{4}{3} \pi r^3 \Delta G_V$. where ΔG_V is the volume free energy change .

(ii) The second is the surface energy, results from the formation of the nucleation of a spherical solid particle in a liquid, i.e. $4 \pi r^2 \gamma$.

Finally, the total free energy change (ΔG) is equal to the sum of these two contributions—that is

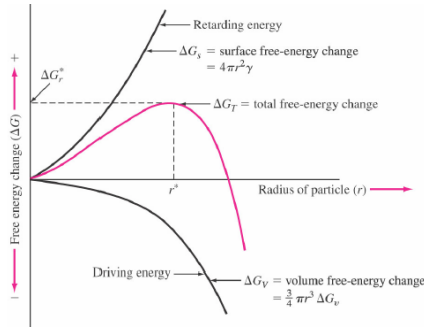

$$\Delta G = \frac{4}{3}\pi r^3 \Delta G_V + 4\pi r^2 \gamma \dots (1)$$

Critical Radius(r*)-

Differentiate the equation (Equation 1) with respect to *r*, set the resulting expression equal to zero, and then solve for critical radius (*r**). That is and activation free energy (Δ*G**)

$$r^* = \frac{-2\gamma}{\Delta G_v} = \frac{-2\gamma T_f}{\Delta H_f \Delta T}$$

$$\Delta G^* = \frac{16\pi\gamma^3}{3\Delta G_v} = \frac{16\pi\gamma^3 T_f^2}{3\Delta H_f^2 \Delta T}$$

When radius (*r*) is less than critical radius (*r**), termed as an embryo. and when radius (*r*) is greater than critical radius (*r**), termed as an nuclei.

Heterogeneous nucleation

Heterogeneous nucleation forms at preferential sites such as phase boundaries, surfaces (of container, bottles, etc.) or impurities like dust. At such preferential sites, the effective surface energy is lower, thus diminishes the free energy barrier and facilitating nucleation. Heterogeneous nucleation occurs much more often than homogeneous nucleation.

Let us consider the nucleation, on a flat solid particle from a liquid phase. It is both the liquid and solid phases “wet” this that is, both of these phases spread out and surface. Taking a surface tension force the plane of the flat surface leads to the expression:

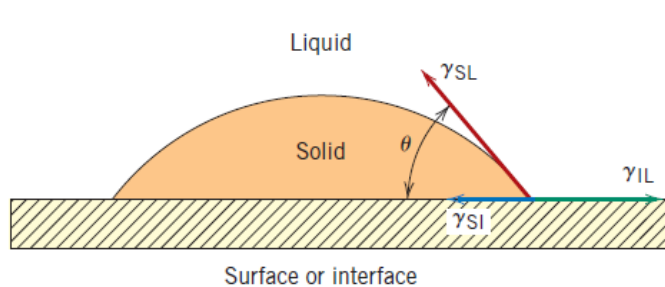

surface, of a assumed that flat surface, cover the balance in following

$$\gamma_{IL} = \gamma_{SI} + \gamma_{SL} \cos \theta$$

where, γ_{IL} , γ_{SI} and γ_{SL} is the interfacial energy between interface- liquid, solid –interface and solid –liquid respectively. And θ is the contact angle.

$$r^* = -\frac{2\gamma_{SL}}{\Delta G_v}$$

$$\Delta G^* = \left(\frac{16\pi\gamma_{SL}^3}{3\Delta G_v^2} \right) S(\theta)$$

Where $S(\theta)$ is the function of contact angle θ as follows:

$$S(\theta) = \frac{(2 + \cos\theta)(1 - \cos\theta)^2}{4}$$

Geometry of Solidification

The chill zone contains fine crystals nucleated at the mould surface. There is then selective growth into the liquid as heat is extracted from the mould. If the liquid in the centre of the mould is undercooled sufficiently there may also be equiaxed grains forming.

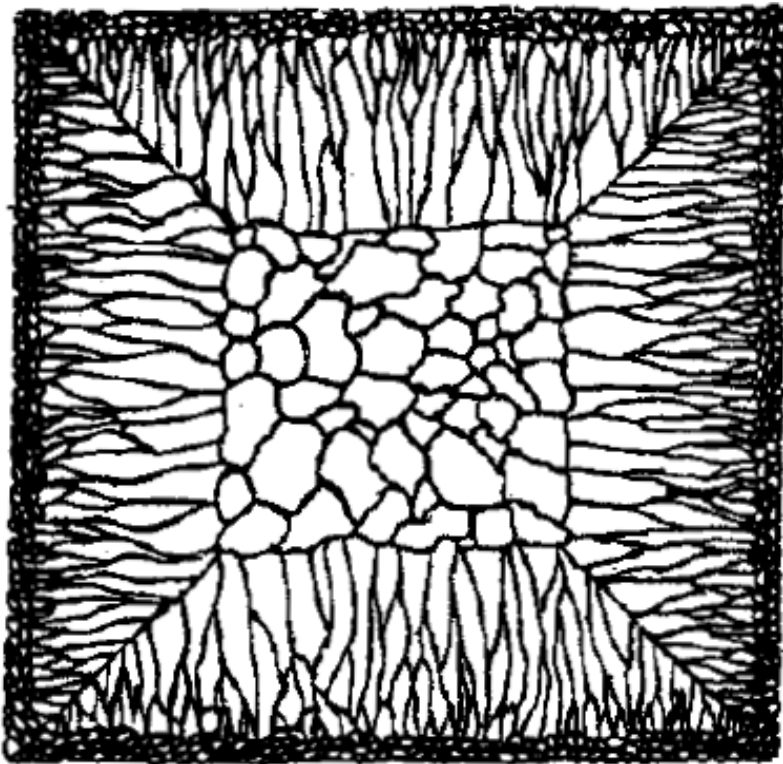

Phase Diagram

Introduction

- Phase diagrams are an important tool in the armory of an materials scientist
- In the simplest sense a phase diagram demarcates regions of existence of various phases. (*Phase diagrams are maps*)
- Phase diagrams are also referred to as “equilibrium diagrams” or “constitutional diagrams”. This usage requires special attention: through the term used is “equilibrium”, in practical terms the equilibrium is *not global equilibrium but Microstructural level equilibrium*.
- Broadly two kinds of phase diagrams can be differentiated*→ those involving time and those which do not involve time.
- In this chapter we shall deal with the phase diagrams not involving time.
 - This type can be further sub classified into:
 - Those with composition as a variable (e.g. T vs. %Composition)
 - Those without composition as a variable (e.g. P vs. T)
- Time-Temperature-Transformation (TTT) diagrams and Continuous-Cooling-Transformation (CCT) diagrams involve time.

Components of a system

- Independent chemical species which comprise the system. These could be Elements, Ions, Compounds
Example: Au-Cu system : Components → Au, Cu (elements)
Ice-water system : Component → H₂O (compound)
Al₂O₃-Cr₂O₃ system : Components → Al₂O₃, Cr₂O₃

Phase

- A physically homogeneous and distinct portion of a material system (e.g. gas, crystal, amorphous...)
- Gases : Gaseous state always a single phase → mixed at atomic or molecule level.
- Liquids: Liquid solution is a single phase → e.g. NaCl in H₂O and Liquid mixtures consists of two or more phases → e.g. Oil in water (*no mixing at the atomic level*)
- Solids: In general due to several compositions and crystals structures many phases are possible.

- For the same composition different crystal structures represent different phases. E.g. *Fe (BCC)* and *Fe (FCC)* are different phases

What kinds of phases exist?

- Based on state → Gas, Liquid, Solid
- Based on atomic order → Amorphous, Quasi-crystalline, Crystalline
- Based on band structure → Insulating, Semi-conducting, Semi-metallic, Metallic
- Based on Property → Para-electric, Ferromagnetic, Superconducting
- Based on stability → Stable, Metastable, Unstable
- Also sometimes- Based on size/geometry of an entity → Nanocrystalline, mesoporous, layered.

Phase transformation

- Phase transformation is the change of one phase into another. For example
 - ✓ Water → Ice and α -Fe (BCC) → γ -Fe (FCC)

Grain

- The single crystalline part of polycrystalline metal separated by similar entities by a grain boundary

Solute

- The component of either a liquid or solid solution that is present to a lesser or minor extent; the component that is dissolved in the solvent.

Solvent

- The component of either a liquid or solid solution that is present to a greater or major extent; the component that dissolves the solute.

System

- System has two meanings. First, “system” may refer to a specific body of material or object. Or, it may relate to the series of possible alloys consisting of the same components, but without regard to alloy composition.

Solubility Limit

- For many alloy systems and at some specific temperature, there is a maximum concentration of solute atoms that may dissolve in the solvent to form a solid solution; this is called a Solubility Limit.

Microstructure

- (Phases + defects + residual stress) & their distributions

- Structures requiring magnifications in the region of 100 to 1000 times. (or) The distribution of phases and defects in a material.

Phase diagram

- Map that gives relationship between phases in equilibrium in a system as a function of T, P and composition. *Map demarcating regions of stability of various phases*

Variables/Axis of phase diagrams

- The axes can be:
 - Thermodynamic (T, P, V)
 - Kinetic (t) or Composition variables (C, %X)
- In single component systems (unary systems) the usual variables are T & P
- In phase diagrams used in materials science the usual variable are T & %X
- In the study of phase transformation kinetics TTT diagrams or CCT diagrams are also used where the axis are T & t

System Components

Phase diagrams and the systems they describe are often classified and named for the number (in Latin) of components in the system:

Number of components	Name of system or diagram
<i>One</i>	Unary
<i>Two</i>	Binary
<i>Three</i>	Ternary
<i>Four</i>	Quaternary
<i>Five</i>	Quinary
<i>Six</i>	Sexinary
<i>Seven</i>	Septenary
<i>Eight</i>	Octanary
<i>Nine</i>	Nonary
<i>Ten</i>	Decinary

Experimental Methods

Thermal Analysis: A plot is made of temperature vs. time, at constant composition, the resulting cooling curve will show a change in slope when a phase change occurs because of the evolution of heat by the phase change. This method seems to be best for determining the initial and final temperature of solidification. Phase changes occurring solely in the solid state generally involve only small heat changes, and other methods give more accurate results.

Metallographic Methods: This method consists in heating samples of an alloy to different temperatures, waiting for equilibrium to be established, and then quickly cooling to retain their high temperature structure. The samples are then examined microscopically. This method is difficult to apply to metals at high temperatures because the rapidly cooled samples do not always retain their high temperature structure, and considerable skill is then required to interpret the observed microstructure correctly.

X-ray diffraction: Since this method measures lattice dimensions, it will indicate the appearance of a new phase either by the change in lattice dimension or by the appearance of a new crystal structure. This method is simple, precise, and very useful in determining the changes in solid solubility with temperature.

Gibbs Phase Rule

- The phase rule connects the Degrees of Freedom, the number of components in a system and the number of phases present in a system via a simple equation.
- To understand the phase rule one must understand the variables in the system along with the degrees of freedom.
- We start with a general definition of the phrase “degrees of freedom”.

Degrees of Freedom: The degree of freedom, F , are those externally controllable conditions of temperature, pressure, and composition, which are independently variable and which must be specified in order to completely define the equilibrium state of the system.

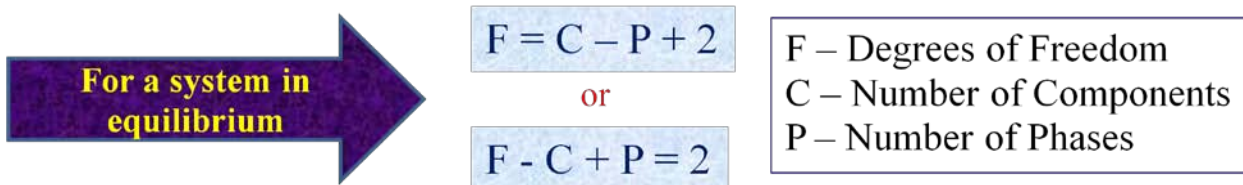

The degrees of freedom cannot be less than zero so that we have an upper limit to the number of phases that can exist in equilibrium for a given system.

Variables in a phase diagram

- C – No. of components
- P – No. of phases
- F – No. of degrees of freedom
- Variables in the system = Composition variables + Thermodynamic variables
- Composition of a phase specified by $(C - 1)$ variables (*If the composition is expressed in %ages then the total is 100% → there is one equation connecting the composition variables and we need to specify only $(C - 1)$ composition variables*)
- No. of variables required to specify the composition of all phases: $P(C - 1)$ (*as there are P phases and each phase needs the specification of $(C - 1)$ variables*)

- Thermodynamic variables = $P + T$ (usually considered) = 2 (at constant pressure (e.g. atmospheric pressure) the thermodynamic variable becomes 1)
- Total no. of variables in the system = $P(C - 1) + 2$
- $F < \text{no. of variables} \rightarrow F < P(C - 1) + 2$ For a system in equilibrium the chemical potential of each species is same in all the phases
- If $\alpha, \beta, \gamma \dots$ are phases, then: $\mu_A(\alpha) = \mu_A(\beta) = \mu_A(\gamma) \dots$
- Suppose there are 2 phases (α and β phases) and 3 components (A, B, C) in each phase then : $\mu_A(\alpha) = \mu_A(\beta), \mu_B(\alpha) = \mu_B(\beta), \mu_C(\alpha) = \mu_C(\beta) \rightarrow$ i.e. there are three equations. For each component there are $(P - 1)$ equations and for C components the total number of equations is $C(P - 1)$. In the above example the number of equations is $3(2 - 1) = 3$ equations.
- $F = (\text{Total number of variables}) - (\text{number of relations between variables})$
- $= [P(C - 1) + 2] - [C(P - 1)] = C - P + 2$
- In a single phase system $F = \text{Number of variables}$
- $P \uparrow \rightarrow F \downarrow$ (For a system with fixed number of components as the number phases increases the degrees of freedom decreases).

Unary Phase Diagram

- Let us start with the simplest system possible: the unary system wherein there is just one component.
- Though there are many possibilities even in unary phase diagram (in terms of the axis and phases), we shall only consider a T-P unary phase diagram.
- Let us consider the water (H_2O) unary diagram
- The Gibbs phase rule here is: $F = C - P + 2$ T&P) (no composition variables here)
- Along the 2 phase co-existence (at B & C) degree of freedom (F) is 1 \rightarrow i.e. we can either T or P and the other will be automatically fixed.
- The 3 phase co-existence points (at A) are points with $F = 0$. (Invariant point implies fixed for a given system).
- The single phase region at point D, T and P can both be varied while still being in the single phase region with $F = 2$.

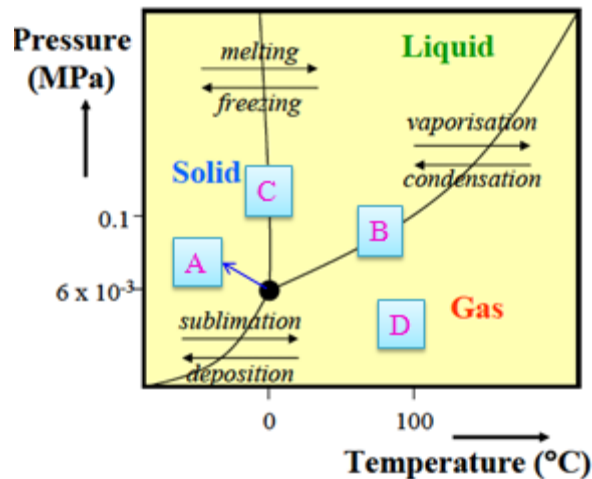

phase
(2 is for
lines the
chose
invariant
they are

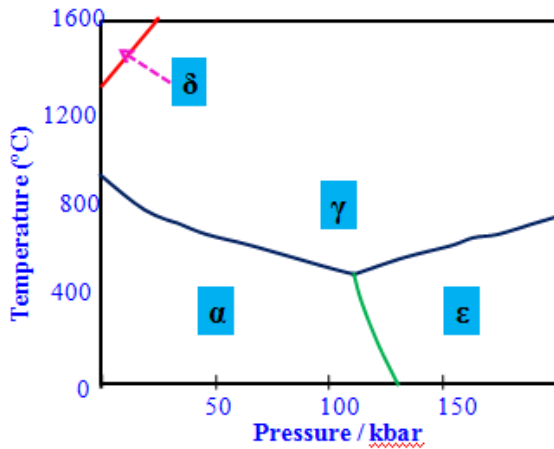

- The above figure represents the phase diagram for pure iron. The triple point temperature and pressure are 490°C and 110 kbars, respectively. α , γ and ϵ refer to ferrite, austenite and ϵ -iron, respectively. δ is simply the higher temperature designation of α .

Binary Phase Diagram

- Binary implies that there are two components.
- Pressure changes often have little effect on the equilibrium of solid phases (unless of course we apply 'huge' pressures).
- Hence, binary phase diagrams are usually drawn at 1 atmosphere pressure.
- The Gibbs phase rule is reduced to:
- Variables are reduced to : $F = C - P + 1$ (1 is for T).
- T & Composition (*these are the usual variables in materials phase diagrams*)

Phase rule for condensed phases

$$F = C - P + 1$$

For T

- In the next page we consider the possible binary phase diagrams. These have been classified based on:
 - ✓ Complete solubility in both liquid & solid states
 - ✓ Complete solubility in both liquid state, but limited solubility in the solid state
 - ✓ Limited solubility in both liquid & solid states

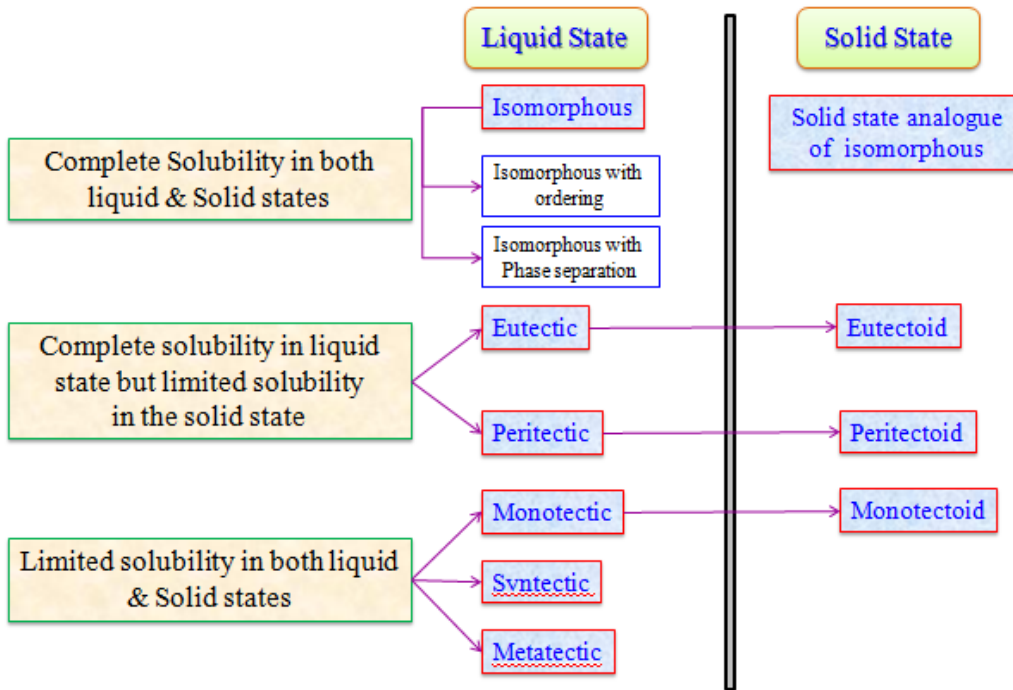

Isomorphous Phase Diagram

- Isomorphous phase diagrams form when there is complete solid and liquid solubility.
- Complete solid solubility implies that the crystal structure of the two components have to be same and Hume-Rothery rules to be followed.
- Examples of systems forming isomorphous systems: Cu-Ni, Ag-Au, Ge-Si, $Al_2O_3-Cr_2O_3$
- Both the liquid and solid contain the components A and B.
- In binary phase diagrams between two single phase regions there will be a two phase region → In the isomorphous diagram between the liquid and solid state there is the (Liquid + Solid) state.
- The Liquid + Solid state is NOT a semi-solid state → it is a solid of fixed composition and structure, in equilibrium with a liquid of fixed composition.
- In some systems (e.g. Au-Ni system) there might be phase separation in the solid state (i.e., the complete solid solubility criterion may not be followed) these will be considered as a variation of the isomorphous system (with complete solubility in the solid and the liquid state).

Cooling curves: Isomorphous system

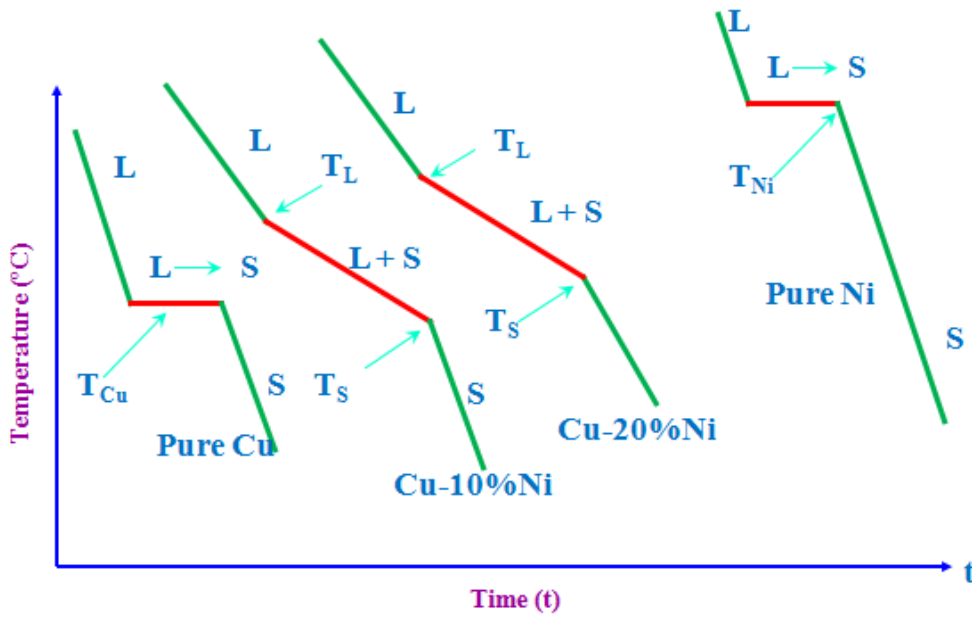

Isomorphous Phase Diagram

T and Composition can both be varied while still being in the single phase region

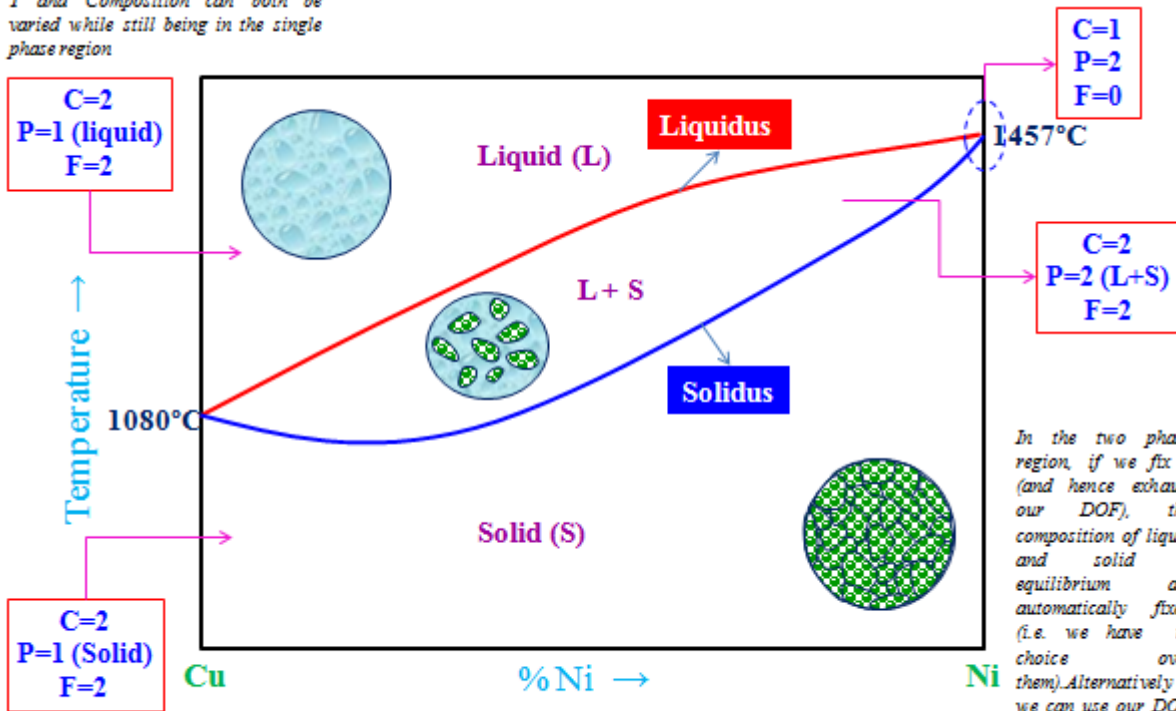

In the two phase region, if we fix T (and hence exhaust our DOF), the composition of liquid and solid in equilibrium are automatically fixed (i.e. we have no choice over them). Alternatively we can use our DOF to chose C₁ then T and C₂ are automatically fixed.

T and Composition can both be varied while still being in the single phase region

Tie line and Lever rule

Chemical Composition of Phases: To determine the actual chemical composition of the phases of an alloy, in equilibrium at any specified temperature in a two phase region, draw a horizontal temperature line, called a *tie line*, to the boundaries of the field. These points of intersection are dropped to the base line, and the composition is read directly.

Relative Amounts of Each Phase:

- To determine the relative amounts of the two phases in equilibrium at any specified temperature in a two phase region, draw a vertical line representing the alloy and a horizontal temperature line to the boundaries of the field.
- The vertical line will divide the horizontal line into two parts whose lengths are inversely proportional to the amount of the phases present. This is also known as *Lever rule*.
- The point where the vertical line intersects the horizontal line may be considered as the *fulcrum* of a lever system.
- The relative lengths of the lever arms multiplied by the amounts of the phases present must balance.

Tie line and Lever rule

- We draw a horizontal line (called the Tie Line) at the temperature of interest (say T_0). Let Tie line is XY.
- Solid (crystal) of composition C_1 coexists with composition C_2
- Note that tie lines can be drawn only in the two coexistence regions (fields). Though they may be extended to mark the temperature.
- To find the fractions of solid and liquid we use rule.
- The portion of the horizontal line in the two region is akin to 'lever' with the fulcrum at the nominal composition (C_0)
- The opposite arms of the lever are proportional to the fraction of the solid and liquid phase present (this is lever rule).

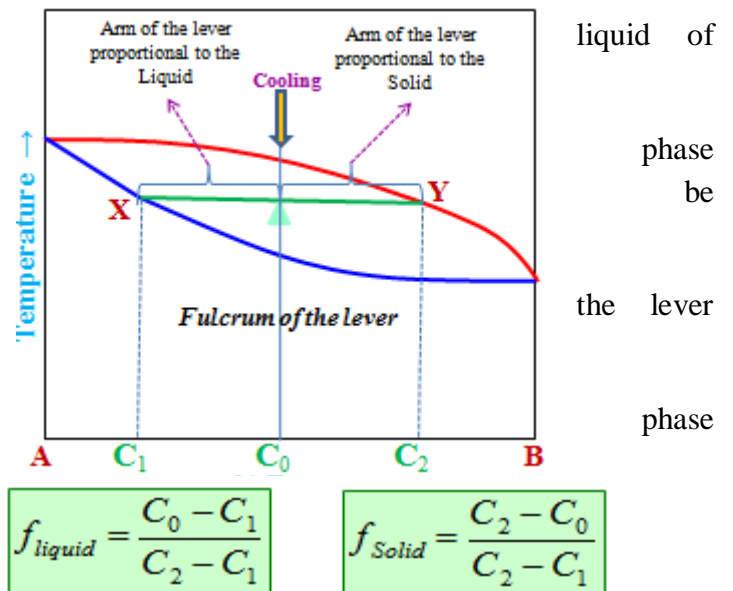

Example

At $C_0 = 35 \text{ wt\% Ni}$

At T_A : Only Liquid (L)

$$W_{\text{liquid}} = 100 \text{ wt\%}, W_{\text{solid}} = 0$$

At T_D : Only Solid (S)

$$W_L = 0, W_{\text{solid}} = 100 \text{ wt\%}$$

At T_B : Both S and L

$$W_L = \frac{S}{R+S} = \frac{43-35}{43-32} = 73 \text{ wt\%}$$

$$W_S = \frac{R}{R+S} = 27 \text{ wt\%}$$

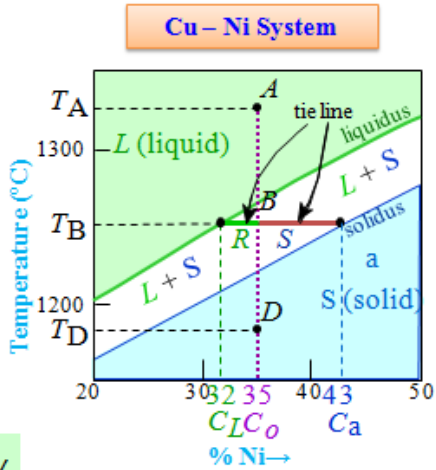

Variations of Isomorphous System

An alloy typically melts over a range of temperatures. However, there are special compositions which can melt at a single temperature like a pure metal. There is no difference in the liquid and solid composition. It begins and ends solidification at a constant temperature with no change in composition, and its cooling curve will show a horizontal line. Such alloys are known as a **congruent-melting alloys**, sometimes known as a **pseudo-eutectic alloy**. Ex: Cu-Au, Ni-Pd.

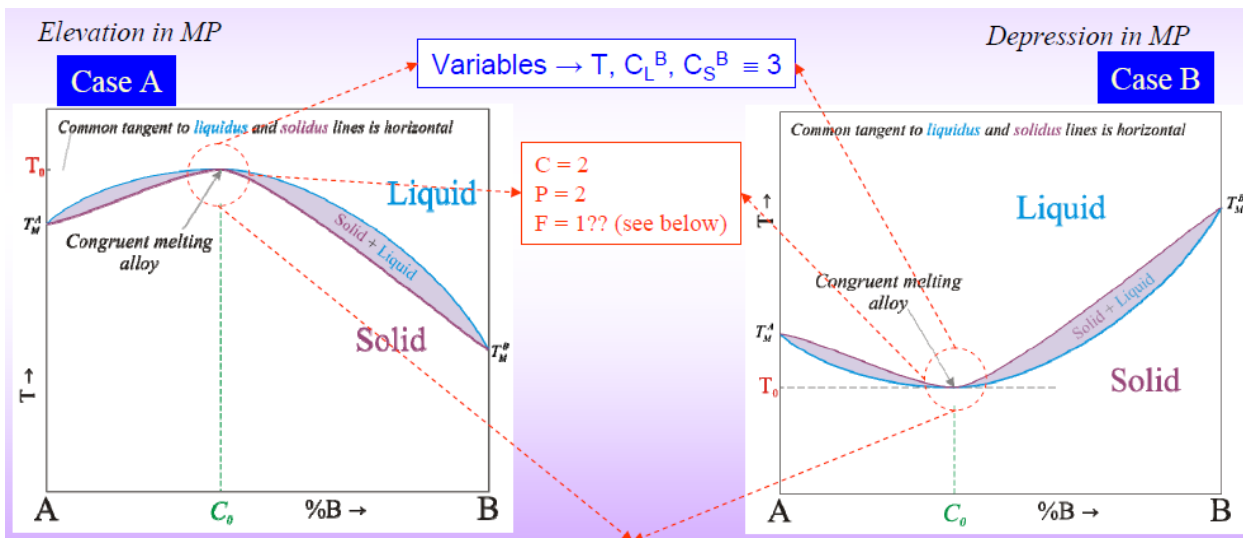

❑ Congruently melting alloys → just like a pure metal

❑ Is the DOF 1? No: in requiring that $C_L^B = C_S^B$ we have exhausted the degree of freedom. Hence T is automatically fixed → DOF is actually Zero..!

Variations of Isomorphous System

- Elevation in the MP means that the solid state is 'more stable' (*crudely speaking the ordered state is more stable*) → ordering reaction is seen at low T.
- Depression in MP 'means' the liquid state (disordered) is more stable → phase separation is seen at low T. (*phase separation can be thought of as the opposite of ordering. Ordering (compound formation) occurs for -ve values for ΔH_{mix}*).

• A - B bonds stronger than A - A and B - B bonds
 • Solid Stabilized → Ordered Solid Formation

• A - A and B - B bonds stronger than A-B bonds
 • Liquid Stabilized → Phase separation in the solid

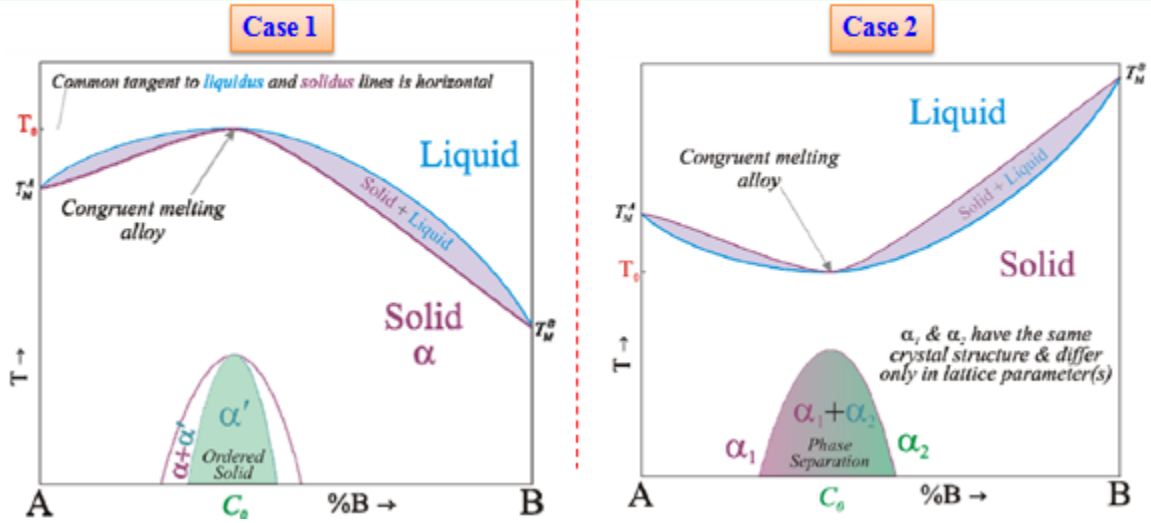

Equilibrium Cooling

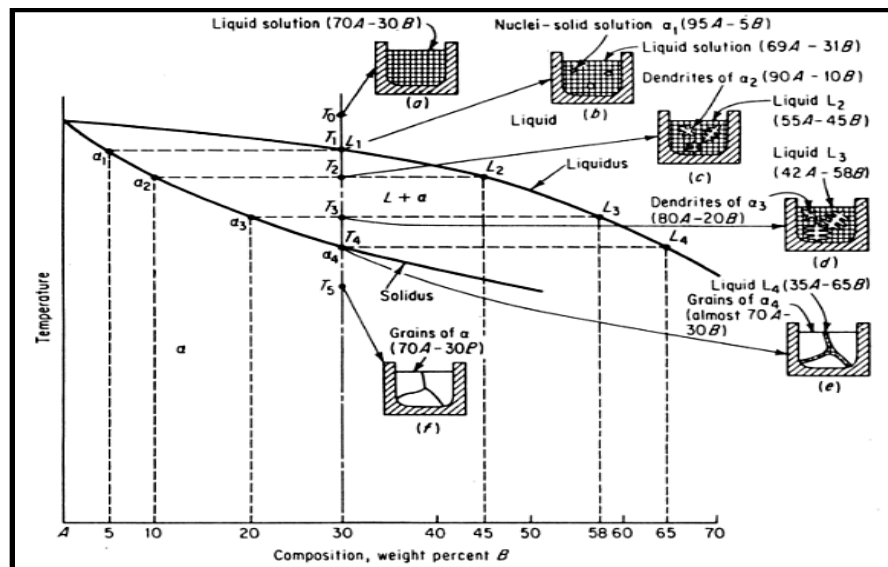
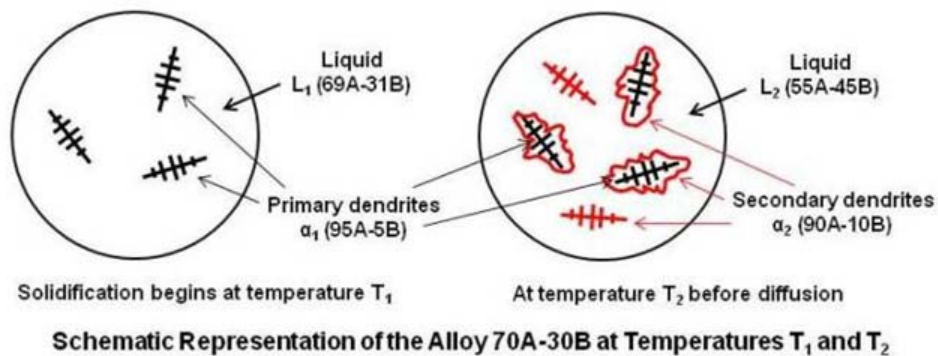

Figure: The above figure represents the very slow cooling, under equilibrium conditions, of a particular alloy 70A-30B will now be studied to observe the phase changes that occur

- This alloy at temperature T_0 is a homogeneous single-phase liquid solution (α) and remains so until temperature T_1 is reached. Since T_1 is on the liquidus line, freezing or solidification now begins.

- The first nuclei of solid solution to form α_1 will be very rich in the higher melting point metal A and will be composed of 95A-5B (by tie line rule). Since the solid solution in forming takes material very rich in A from the liquid, the liquid must get richer in B. Just after the start of solidification, the composition of the liquid is approximated as 69A-31B (b).
- When the lower temperature T_2 is reached, the liquid composition is at L_2 . The only solid solution in equilibrium with L_2 and therefore the only solid solution forming at T_2 is α_2 . Applying tie line rule, α_2 is composed of 10B. Hence, as the temperature is decreased, not only does the liquid composition become richer in B but also the solid solution.
- At T_2 , crystals of α_2 are formed surrounding the α_1 composition cores and also separate dendrites of α_2 (see figure in below).



- In order for equilibrium to be established at T_2 , the entire solid phase must be a composition α_2 . This requires diffusion of B atoms to the A-rich core not only from the solid just formed but also from the liquid. This is possible in crystal growth (c).
- The composition of the solid solution follows the solidus line while the composition of liquid follows the liquidus line, and both phases are becoming richer in B.
- At T_3 (d), the solid solution will make up approximately three-fourths of all the material present.
- Finally, the solidus line is reached at T_4 , and the last liquid L_4 , very rich in B, solidifies primarily at the grain boundaries (e).
- However, diffusion will take place and all the solid solution will be of uniform composition α (70A-30B), which is the overall composition of the alloy (f).
- There are only grains and grain boundaries. There is no evidence of any difference in chemical composition inside the grains, indicating that diffusion has made the grain homogeneous.

- ❑ The very slow cooling, under equilibrium conditions, of particular alloy 65Cu - 35Ni will now be studied.
- A – Homogeneous single phase (Liquid)
- B - ‘B’ is on the liquidus line, solidification now begins.
- C – Solid surrounded by liquid crystals.
- D – ‘D’ is on the solidus line, solidification now ends.
- E – Homogeneous single phase (Solid)

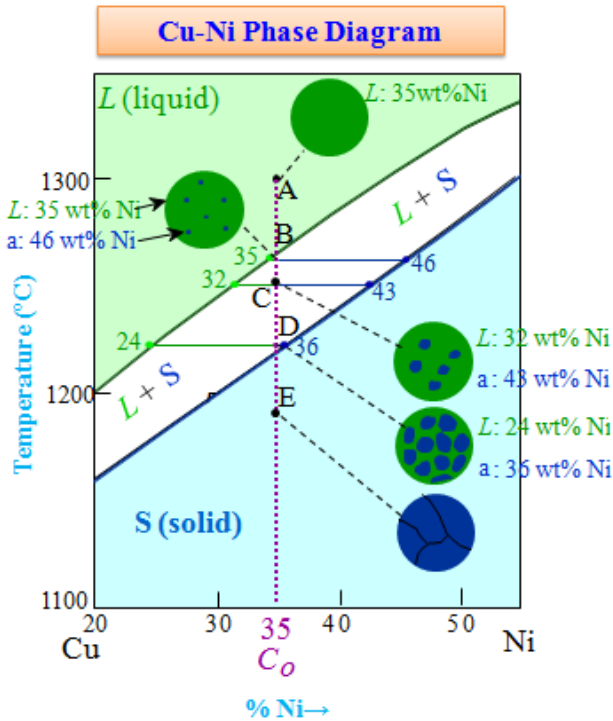

Non Equilibrium Cooling - Coring

- ❑ In actual practice it is extremely difficult to cool under equilibrium conditions. Since diffusion in the solid state takes place at a very slow rate, it is expected that with ordinary cooling rates there will be some difference in the conditions as indicated by the equilibrium diagram.
- ❑ Consider again 70A-30B alloy, solidification starts at T_1 forming a solid solution of composition α_1 .
- ❑ At T_2 the liquid is L_2 and the solid solution now is of composition α_2 . Since diffusion is too slow pace with crystal growth, not enough time will be allowed to achieve uniformity in the solid, and average composition will be between α_1 and α_2 .
- ❑ As the temperature drops, the average composition of the solid solution will depart still further from equilibrium conditions. It seems that the composition of the solid solution is following a “nonequilibrium” solidus line α_1 to α'_5 , shown dotted lines in figure.
- ❑ The liquid, on the other hand, has essentially the composition given by the liquidus line, since diffusion is relatively rapid in liquid. At T_3 the average solid solution will be of composition α'_3 instead of α_3 .
- ❑ Under equilibrium cooling, solidification should be complete at T_4 ; however, since the average composition of the solid solution α'_4 has not reached the composition of the alloy, some liquid must still remain. Applying lever rule at T_4 gives $\alpha'_4 = 75\%$ and $L_4 = 25\%$.

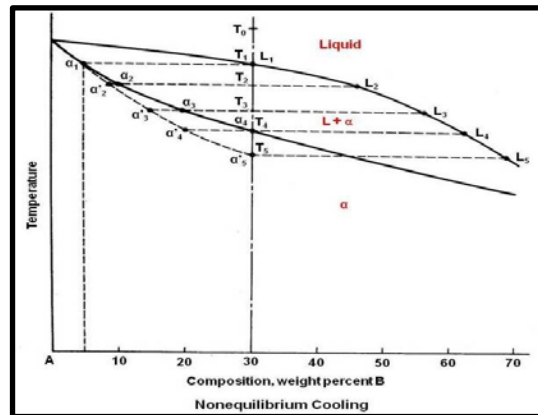

starts at T_1 forming to keep be the say α'_2 .

further

- ❑ Therefore, solidification will continue until T_5 is reached. At this temperature the composition of the solid solution α'_5 coincides with the alloy composition, and solidification is complete. The last liquid to solidify, L_5 , is richer in B than the last liquid to solidify under equilibrium conditions.
- ❑ *The more rapidly the alloy is cooled the greater will be the composition range in the solidified alloy. Since the rate of chemical attack varies with composition, proper etching will reveal the dendritic structure microscopically (see below figure). The final solid consists of a “cored” structure with a higher-melting central portion surrounded by the lower-melting, last-to-solidify shell. The above condition is referred to as coring or dendritic segregation.*
- ❑ To summarize, nonequilibrium cooling results in an increased temperature range over which liquid and solid are present; Since diffusion has not kept pace with crystal growth, there will be a difference in chemical composition from the center to the outside of the grains. The faster the rate of cooling, the greater will be the above effects.

Eutectic Phase Diagram

- Very few systems exhibit an isomorphous phase diagram (usually the solid solubility of one component in another is limited).
- Often the solid solubility is severely limited – through the solid solubility is never zero (due to entropic reasons).
- In a Simple eutectic system (binary), there is one composition at which the liquid freezes at a single temperature. This is in some sense similar to a pure solid which freezes at a single temperature (unlike a pure substance the freezing produces a two solid phases both of which contain both the components).
- The term Eutectic means easy melting → The alloy of eutectic composition freezes at a lower temperature than the melting points of the constituent components.
- *This has important implications → e.g. the Pb -Sn eutectic alloy melts at 183 °C, which is lower than the melting points of both Pb (327°C) and Sn (232°C) → Can be used for soldering purposes (as we want to input least amount of heat to solder two materials).*
- In the next page we consider the Pb-Sn eutectic phase diagram.

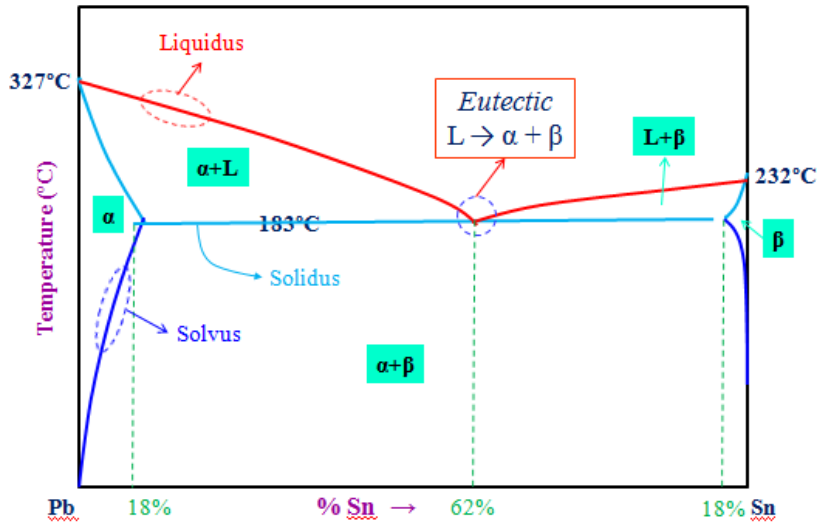

Eutectic reaction at 183°C: $L \rightarrow \alpha + \beta$
 $62\% \text{ Sn} \rightarrow 18\% \text{ Sn} + 97\% \text{ Sn}$

Microstructural Characteristics of Eutectic System

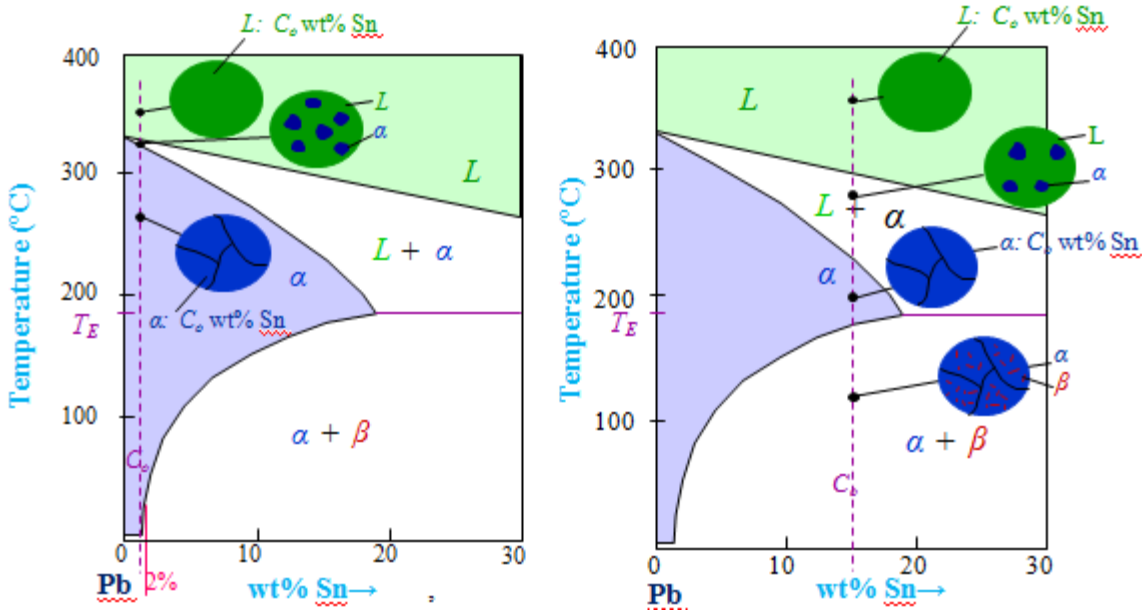

- To reiterate an important point: Phase diagram do not contain microstructural information (i.e. they cannot tell you what the microstructures produced by cooling is. Often microstructural information is overlaid on phase diagram for convenience. Hence, strictly cooling is not in the domain of phase diagram – but we can overlay such information keeping in view the assumptions involved.

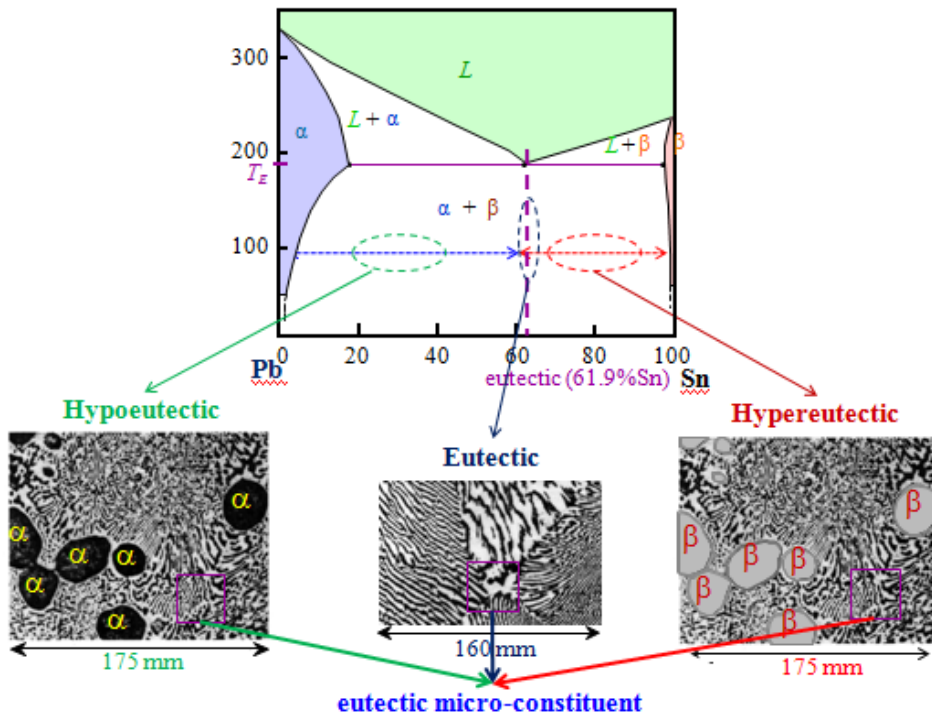

Application of Lever rule in Eutectic System

Solved Example For a 40 wt% Sn-60 wt% Pb alloy at 220°C, find the phases present: α and Liquid, Composition of phases

$C_0 = 40 \text{ wt\% Sn}$
 $C_\alpha = 17 \text{ wt\% Sn}$
 $C_L = 46 \text{ wt\% Sn}$

The relative amount of each phase by using lever rule

$$W_\alpha = \frac{C_L - C_0}{C_L - C_\alpha} = \frac{46 - 40}{46 - 17} = \frac{6}{29} = 21 \text{ wt\%}$$

$$W_L = \frac{C_0 - C_\alpha}{C_L - C_\alpha} = \frac{40 - 17}{46 - 17} = \frac{23}{29} = 79 \text{ wt\%}$$

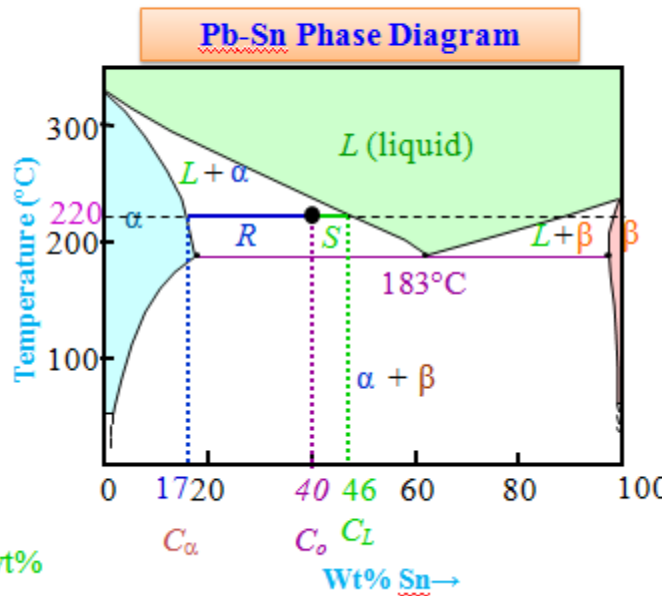

Peritectic Phase Diagram

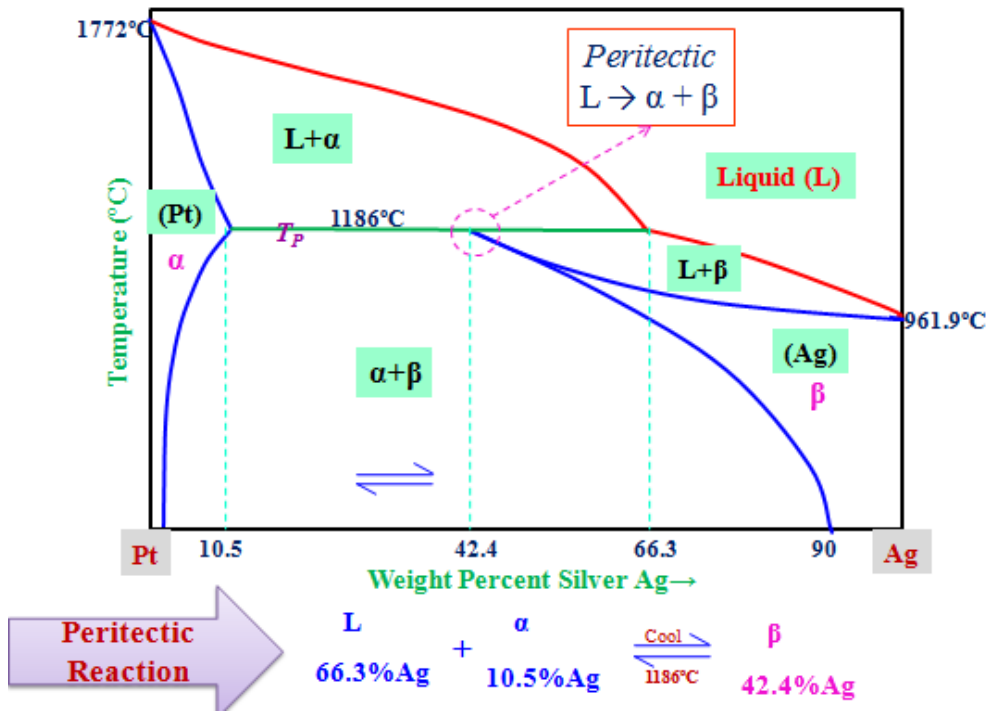

- Like the eutectic system, the Peritectic reaction is found in systems with complete liquid solubility but limited solid solubility.
- In the Peritectic reaction the liquid (L) reacts with one solid (α) to produce another solid (β). $L + \alpha \rightarrow \beta$
- Since the solid β forms at the interface between the L and the α , further reaction is dependent on solid state diffusion. Needless to say this becomes the rate limiting step and hence it is difficult to 'equilibrate' peritectic reactions (as compared to say eutectic reactions).
- In some Peritectic reactions (e.g. the Pt-Ag system – previous page). The (pure) β phase is not stable below the Peritectic temperature ($T_P = 1186^\circ\text{C}$ for Pt- Ag system) and splits into a mixture of ($\alpha + \beta$) just below T_P .

Monotectic Phase Diagram

- In all the types discussed previously, it was assumed that there was complete solubility in the liquid state. It is quite possible, however, that over a certain composition range two liquid solutions are formed that are not soluble in each other.
- Another term for solubility is miscibility. Substances that are not soluble in each other, such as oil and water, are said to be immiscible. Substances that are partly soluble in each other are said to show a miscibility gap, and this is related to Monotectic Systems.
- When one liquid forms another liquid, plus a solid, on cooling, it is known as a *Monotectic Reaction*.
- It should be apparent that the Monotectic reaction resembles the eutectic reaction, the only difference being that one of the products is a liquid phase instead of a solid phase.

- An example of an alloy system showing a Monotectic reaction is that between *copper and lead* given in next page. Notice that in this case the $L_1 + L_2$ is closed.
- Also, although the terminal solids are indicated as α and β , the solubility is actually so small that they are practically the pure metals, copper and lead.

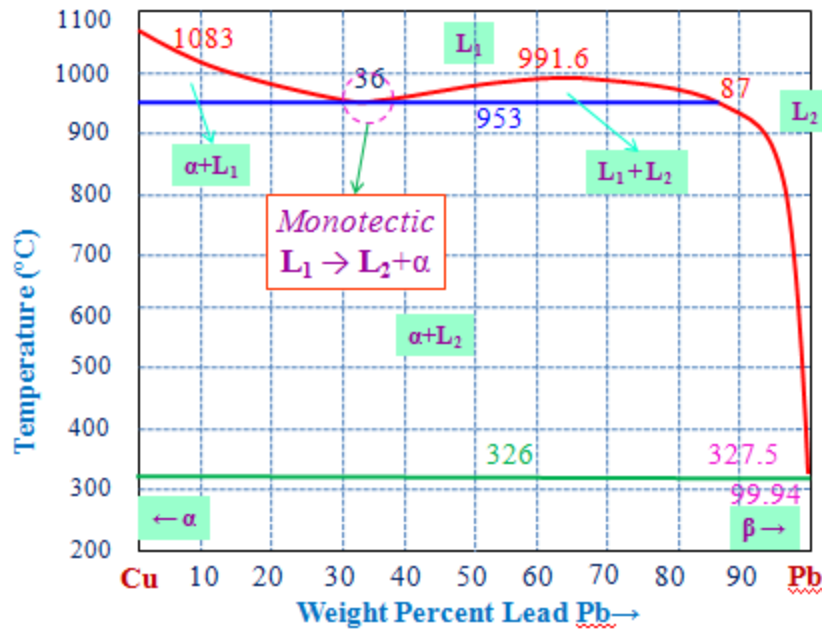

The Eutectoid Reaction

- ❑ This is a common reaction in the solid state. It is very similar to the eutectic reaction but does not involve the liquid. In this case, a solid phase transforms on cooling into two new solid phases. The general equation may be written as..!
- ❑ The resultant Eutectoid mixture is extremely fine, just like the eutectic mixture. Under the microscope both mixtures generally appear the same, and it is not possible to determine microscopically whether the mixture resulted from a eutectic reaction or eutectoid reaction.
- ❑ An equilibrium diagram of Cu-Zn, illustrating the eutectoid reaction is shown in figure.
- ❑ In copper (Cu) – Zinc (Zn) system contains two terminal solid solutions i.e. these are extreme ends of phase diagram α and η , with four intermediate phases called β , γ , δ and ϵ . The β' phase is termed an ordered solid solution, one in which the copper and zinc atoms are situated in a specific and ordered arrangement within each unit cell.

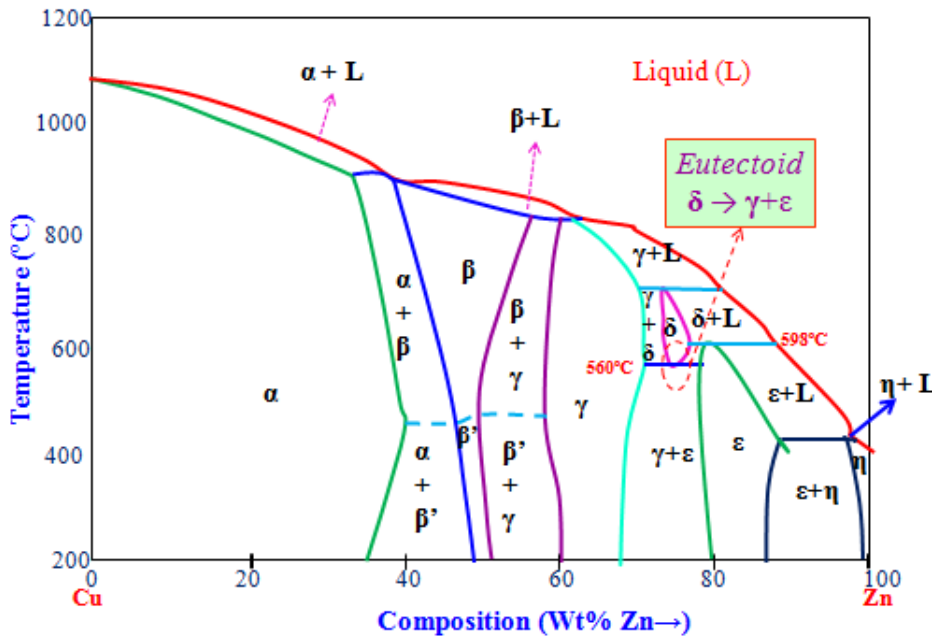

- In the diagram, some phase boundary lines near the bottom are dashed to indicate that these positions have not been exactly determined. The reason for this is that at low temperatures, diffusion rates are very slow and inordinately long times are required for the attainment of equilibrium.
- Again only single- and two- phase regions are found on the diagram, and the same and we can utilize the lever rule for computing phase compositions and relative amounts.
- The commercial material brasses are copper-rich copper-zinc alloys: for example, cartridge brass has a composition of 70 wt% Cu-30 wt% Zn and a microstructure consisting of a single α phase.

In Cu-Zn Phase diagram the eutectoid reaction occurs at 560 °C with 75% Zn

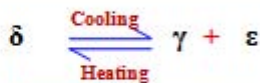

Cu 70, Zn 30 (wt%),
recrystallized
annealing twins



The Peritectoid Reaction

- This is a fairly common reaction in the solid state and appears in many alloy systems. The peritectoid reaction may be written as



- The new solid phase is usually an intermediate alloy, but it may also be a solid solution. The peritectoid reaction has the same relationship to the peritectic reaction as the eutectoid has to the eutectic. Essentially, it is the replacement of a liquid by a solid.

- The peritectoid reaction occurs entirely in the solid state and usually at lower temperatures than the peritectic reaction, the diffusion rate will be slower and there is less likelihood that equilibrium structures will be reached.
- Consider Silver (Ag) – Aluminium (Al) phase diagram (*in next page*) containing a peritectoid reaction.
- If a 7% Al alloy is rapidly cooled from the two phase area just above the peritectoid temperature the two phases will be retained, and the microstructure will show a matrix of γ with just a few particles of α . When we cool at below the peritectoid temperature by holding we get single phase μ .

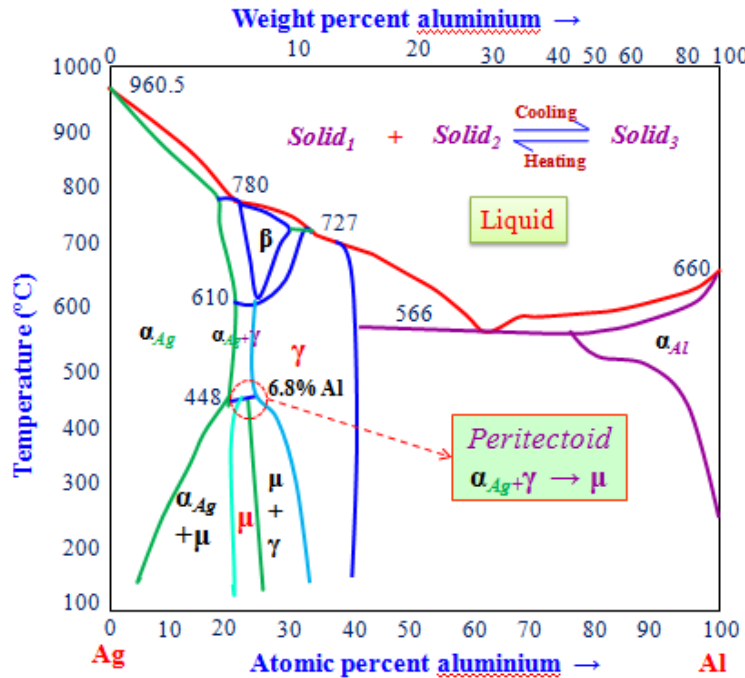

Monotectoid Reaction : Al-Zn Phase Diagram

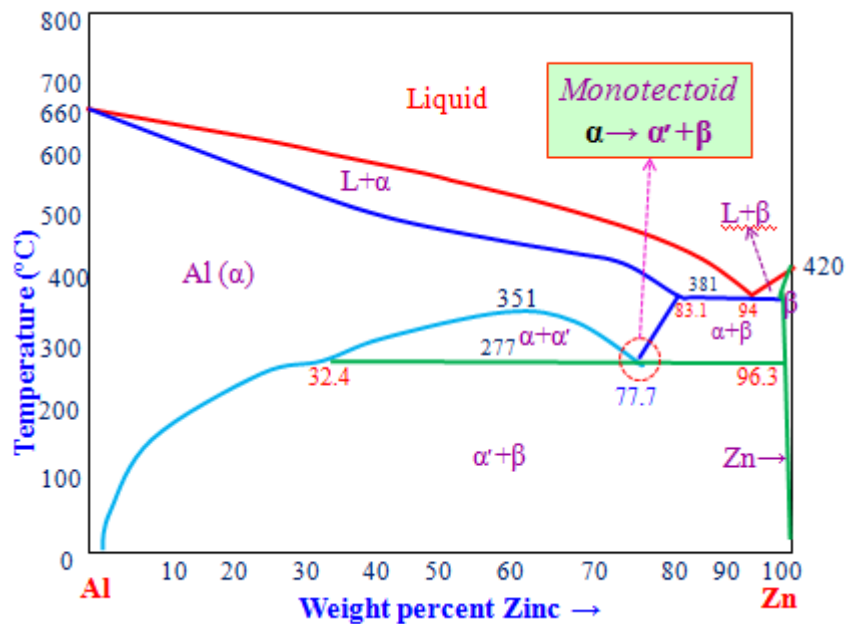

Synthetic Reaction : Ga – I Phase Diagram

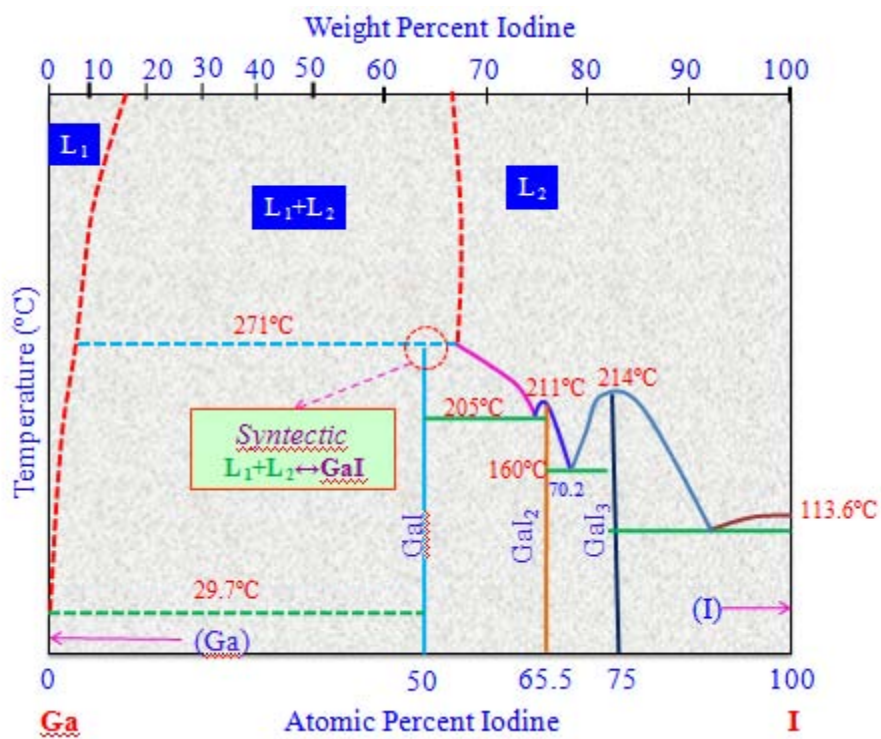

Summary of Invariant reactions

Name of reaction	Phase equilibrium	Schematic representation
Eutectic	$L \leftrightarrow S_1 + S_2$	
Peritectic	$S_1 + L \leftrightarrow S_2$	
Monotectic	$L_1 \leftrightarrow S_1 + L_2$	
Eutectoid	$S_1 \leftrightarrow S_2 + S_3$	
Peritectoid	$S_1 + S_2 \leftrightarrow S_3$	
Monotectoid	$S_{1a} \leftrightarrow S_{1b} + S_2$	
Metatectic	$S_1 \leftrightarrow S_2 + L$	
Syntectic	$L_1 + L_2 \leftrightarrow S$	

Allotropic Transformations

- As we discussed earlier that several metals may exist in more than one type of crystal structure depending upon temperature, Iron, Tin, Manganese and Cobalt are examples of metals which exhibit this property, known as *Allotropy*.
- On an equilibrium diagram, this allotropic change is indicated by a point or points on the vertical line which represents the pure metal. This is illustrated in below figure. In this diagram, the gamma solid solution field is 'looped'. The pure metal Fe and alloys rich in Fe undergo two transformations.

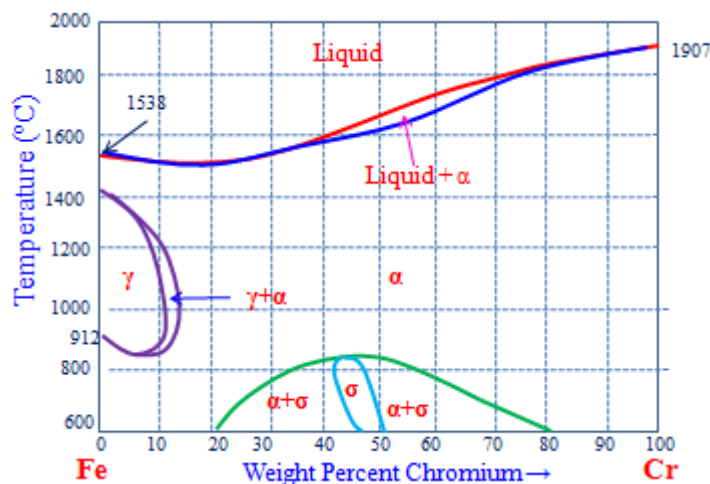

Order-disorder Transformations

- Ordinarily in the formation of substitutional type of solid solution the solute atoms do not occupy any specific position but are distributed at random in the lattice structure of the solvent. The alloy is said to be in a 'disordered' condition.

- Some of these random solid solutions, if cooled slowly, undergo a rearrangement of the atoms where the solute atoms move into definite positions in the lattice. This structure is known as an *ordered solid solution or superlattice*.
- Ordering is most common in metals that are completely soluble in the solid state, and usually the maximum amount of ordering occurs at a simple atomic ratio of the two elements.
- For this reason, the ordered phase is sometimes given a chemical formula, such as AuCu and AuCu₃ in the gold-copper alloy system. On the equilibrium diagram, the ordered solutions are frequently designated as α' , β' , etc. or α'' , α''' , etc., and the area in which they are found is usually bounded by a dot-dash line.

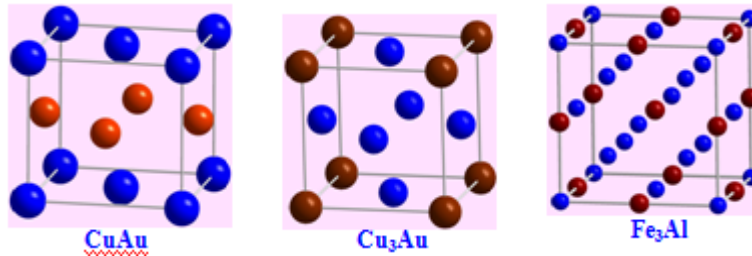

- When the ordered phase has the same lattice structure as the disordered phase, the effect of ordering on mechanical properties is negligible. Hardening associated with the ordering process is most pronounced in those systems where the shape of the unitcell is changed by ordering.
- Regardless of the structure formed as a result of ordering, an important property change produced, even in the absence of hardening, is a significant reduction in electrical resistance. Notice the sharp decrease in electrical resistivity at the compositions which correspond to the ordered phases AuCu and AuCu₃.

Allotropic

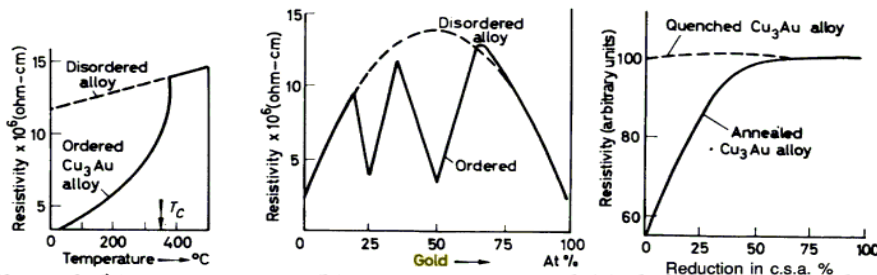

Transformations in Iron

- Iron is an allotropic metal, which means that it can exist in more than one type of lattice structure depending upon temperature. A cooling curve for pure iron is shown below:

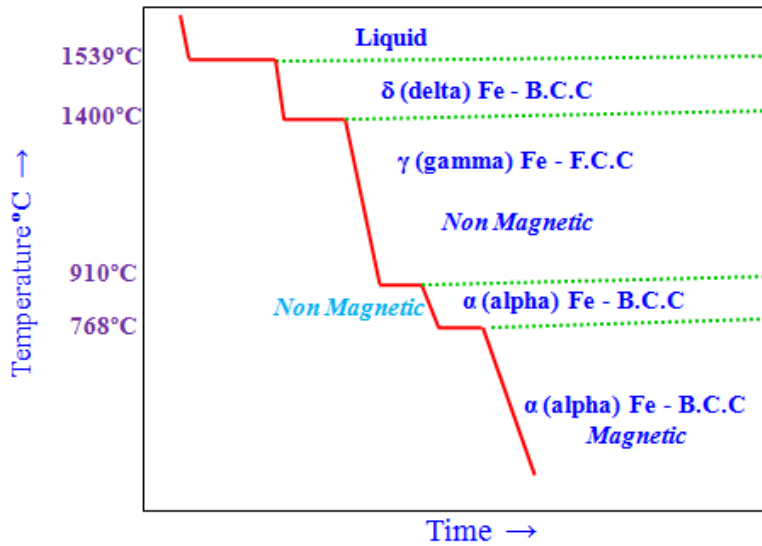

Iron – Cementite Phase Diagram

- The Fe-C (or more precisely the Fe-Fe₃C) diagram is an important one. Cementite is a metastable phase and ‘strictly speaking’ should not be included in a phase diagram. But the decomposition rate of cementite is small and hence can be thought of as ‘stable enough’ to be included in a phase diagram. Hence, we typically consider the Fe-Fe₃C part of the Fe-C phase diagram.
- A portion of the Fe-C diagram – the part from pure Fe to 6.67 wt.% carbon (*corresponding to cementite, Fe₃C*) – is *technologically very relevant*.
- Cementite is not an equilibrium phase and would tend to decompose into Fe and graphite. This reaction is sluggish and for practical purpose (at the microstructural level) cementite can be considered to be part of the phase diagram. Cementite forms as it nucleates readily as compared to graphite.
- Compositions upto 2.1%C are called steels and beyond 2.1% are called cast irons. *In reality the classification should be based on ‘castability’ and not just on carbon content.*
- Heat treatments can be done to alter the properties of the steel by modifying the microstructure → we will learn about this in coming chapters.

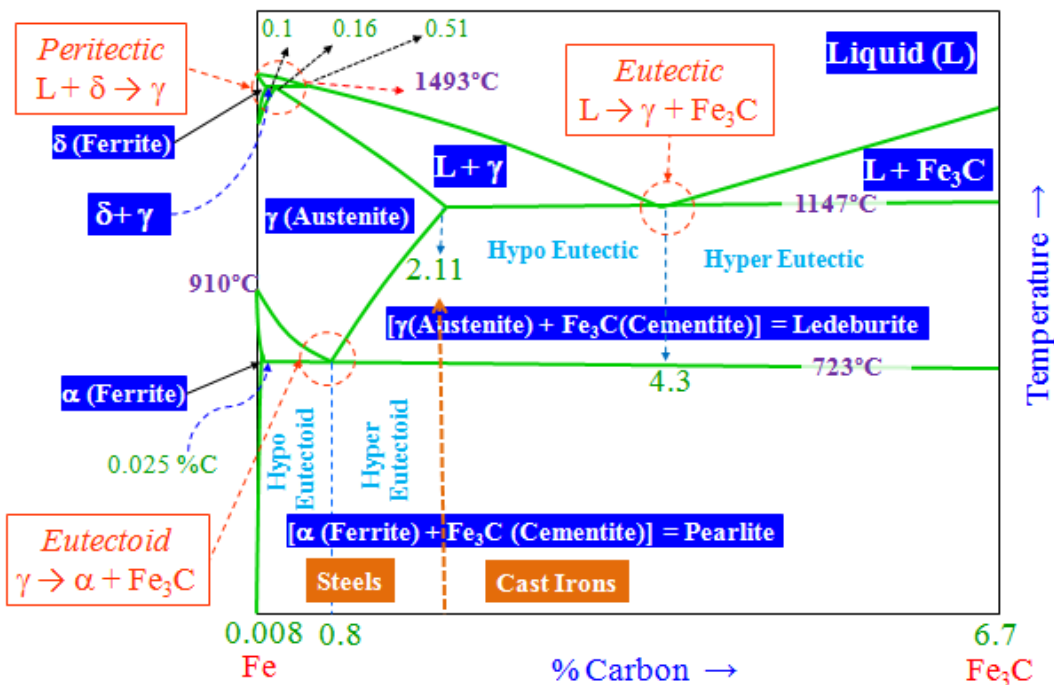

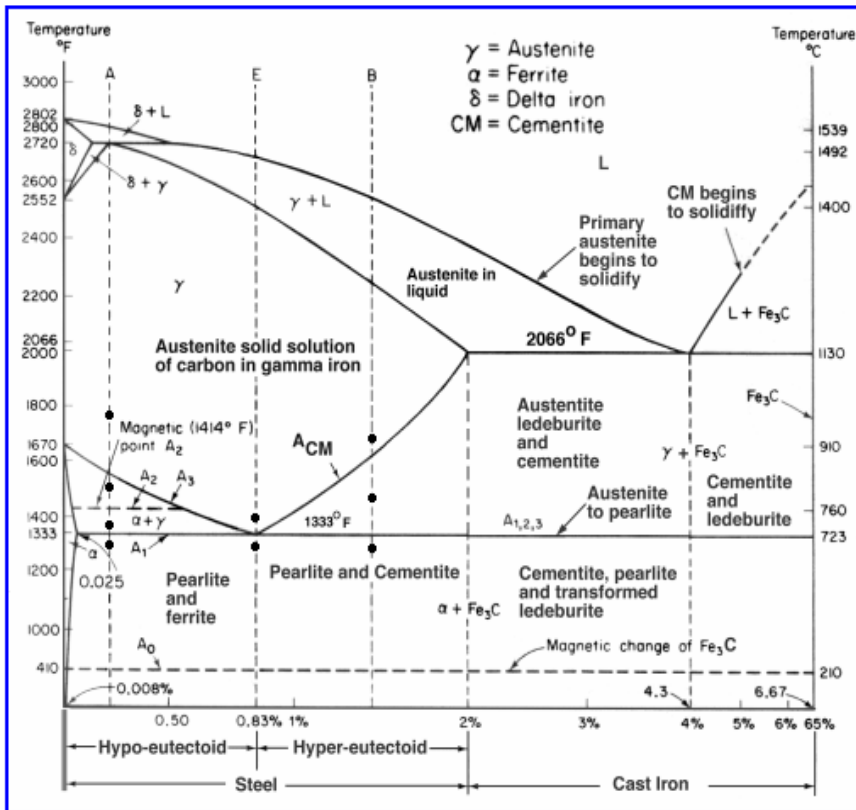

Figure: Iron – Cementite Phase Diagram

Carbon Solubility in Iron

Solubility of carbon in Fe = f (structure, temperature)

Where is carbon located in iron lattice?

BCC

6 faces sharing with two sides (6/2)=3
12 edges sharing with four sides (12/4)=3
Total sites is (3+3), 6 per unit cell
Every one Fe atom we have 3 interstitial sites

FCC

One interstitial site in center plus
12 edges sharing with four sides (12/4)=3
Total sites is (1+3), 4 per unit cell
Every one Fe atom we have 1 interstitial site

Characteristics of phases appeared in Fe-Fe₃C phase diagram

Ferrite (α)

- It is an interstitial solid solution of a small amount of dissolved in α iron. The maximum solubility is 723°C and it dissolves only 0.008%C at room temperature. *It is the softest structure that appears on the diagram*
- The crystal structure of ferrite (α) is B.C.C
- Tensile strength – 40,000 psi or 275 Mpa
- Elongation – 40% in 2 in.
- Hardness - < 0 HRC or < 90 HRB

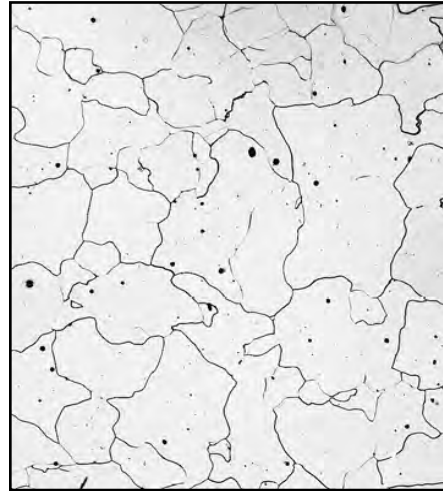

carbon
0.025%C at
temperature.

Cementite (Fe₃C)

- Cementite or iron carbide, chemical formula Fe₃C, contains 6.67%C by weight and it is a metastable phase.
- It is typically hard and brittle interstitial compound of low tensile strength (approx. 5000 psi) but high compressive strength.
- It is the hardest structure that appears on the diagram.
- Its crystal structure is orthorhombic

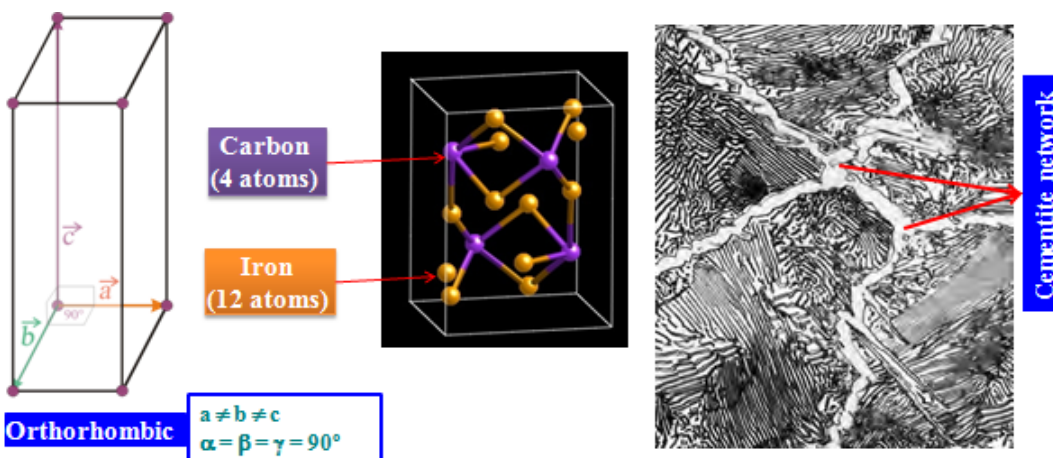

Pearlite ($\alpha + \text{Fe}_3\text{C}$)

- ❑ Pearlite is the eutectoid mixture containing 0.80 %C and is formed at 723°C on very slow cooling.
- ❑ It is very fine platelike or lamellar mixture ferrite and cementite. The fine fingerprint called pearlite is shown in below figure.
- ❑ Tensile strength – 120,000 psi or 825 Mpa
- ❑ Elongation – 20 percent in 2 in.
- ❑ Hardness – HRC 20, HRB 95-100, or 250-300

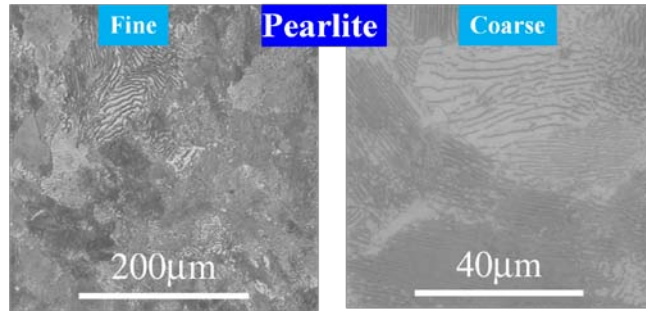

of
mixture

BHN

Austenite (γ)

- ❑ It is an interstitial solid solution of a small amount of dissolved in γ iron. The maximum solubility is 2.1% C at
- ❑ The crystal structure of Austenite (γ) is F.C.C
- ❑ Tensile strength – 150,000 psi or 1035 Mpa
- ❑ Elongation – 10% in 2 in.
- ❑ Hardness - 40 HRC and Toughness is high.

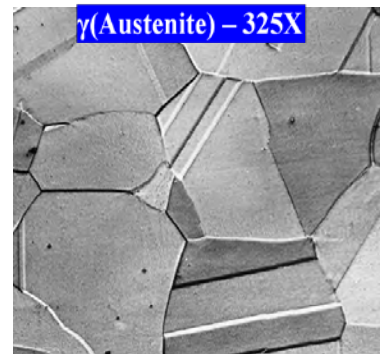

carbon
1147°C.

Ledeburite ($\gamma + \text{Fe}_3\text{C}$)

- Ledeburite is the eutectic mixture of austenite It contains 4.3% C and is formed at 1147°C
- Structure of ledeburite contains small islands of dispersed in the carbide phase.
- Not stable at room temperature

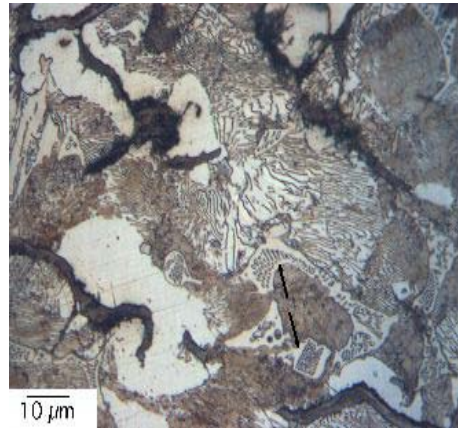

and cementite.
austenite are

Ferrite (δ)

- Interstitial solid solution of carbon in iron of centered cubic crystal structure. (δ iron) of lattice parameter (2.89Å) having solubility 0.09 wt% at 1495°C with respect to austenite. stability of the phase ranges between 1394-

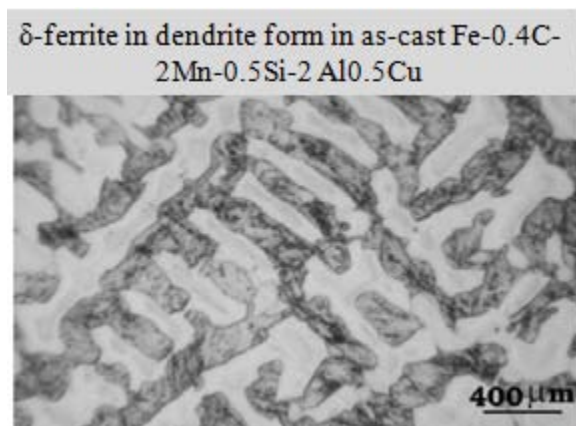

body
higher
limit of
The
1539°C.

- This is not stable at room temperature in plain carbon steel. However it can be present at room temperature in alloy steel especially duplex stainless steel.

Microstructures involved in eutectoid mixture \

Eutectoid reaction

- Phase changes that occur upon passing from the γ region into the $\alpha + \text{Fe}_3\text{C}$ phase field.
- Consider, for example, an alloy of eutectoid composition (0.8% C) as it is cooled from a temperature within the γ region, say 800°C – that is, beginning at point ‘a’ in figure moving down vertical xx’. Initially the alloy is composed entirely of the austenite phase having composition 0.8 wt.% then transformed to $\alpha + \text{Fe}_3\text{C}$ [pearlite]
- The microstructure for this eutectoid steel that is slowly through eutectoid temperature consists of alternating layers lamellae of the two phases α and Fe_3C
- The pearlite exists as grains, often termed “colonies”; within each colony the layers are oriented in essentially the same direction, which varies from one colony to other.
- The thick light layers are the ferrite phase, and the cementite phase appears as thin lamellae most of which appear dark.

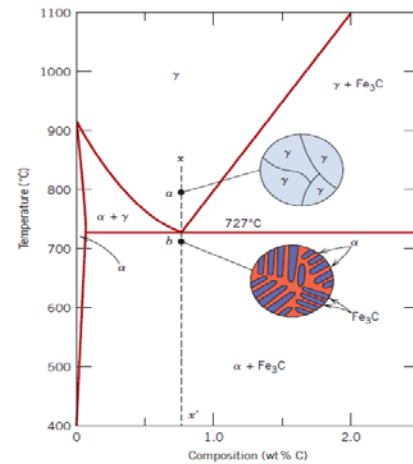

into phase and C and cooled or

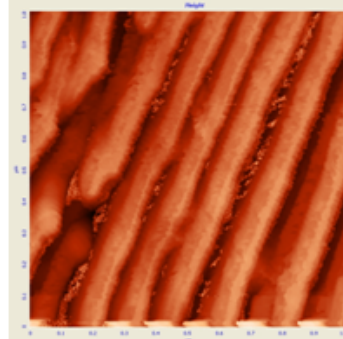
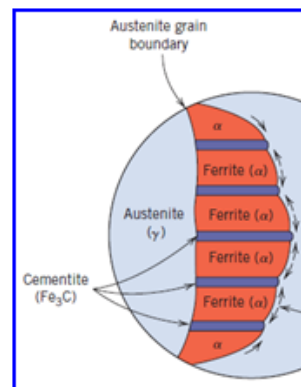
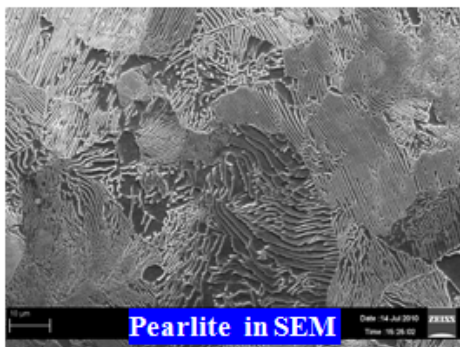

Pearlite in AFM

Pearlite in optical microscope

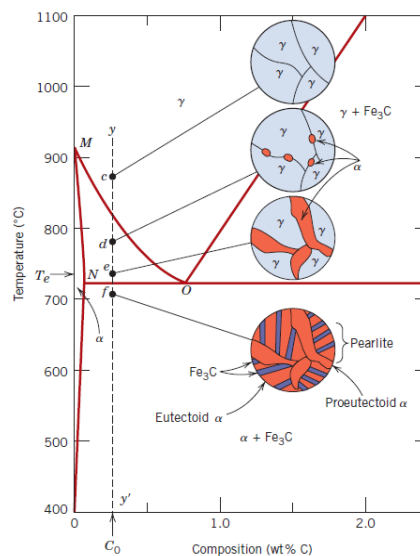

Hypo eutectoid region

- ❑ Hypo eutectoid region – 0.008 to 0.8 %C
- ❑ Consider vertical line yy' in figure, at about 875°C , point c , the microstructure will consist entirely of grains of the γ phase.
- ❑ In cooling to point d , about 775°C , which is within the $\alpha+\gamma$ phase region, both these phases will coexist as in the schematic microstructure. Most of the small α particles will form along the original γ grain boundaries.
- ❑ Cooling from point d to e , just above the eutectoid but still in the $\alpha+\gamma$ region, will produce an increased fraction of the α phase and a microstructure similar to that also shown: the α particles will have grown larger.
- ❑ Just below the eutectoid temperature, at point f , all the γ phase that was present at temperature e will transform pearlite. Virtually there is no change in α phase that existed at point e in crossing the eutectoid temperature – it will normally be present as a continuous matrix phase surrounding the isolated pearlite colonies.
- ❑ Thus the ferrite phase will be present both in the pearlite and also as the phase that formed while cooling through the $\alpha+\gamma$ phase region. The ferrite that is present in the pearlite is called eutectoid ferrite, whereas the other, is termed proeutectoid (meaning pre- or before eutectoid) ferrite.

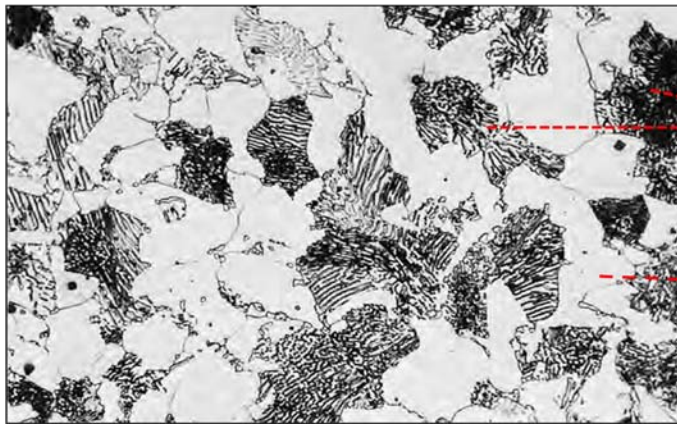

Pearlite

Pro-eutectoid ferrite

Hyper eutectoid region

- Hyper eutectoid region – 0.8 to 2.1 %C
- Consider an alloy of composition C_1 in figure that, cooling, moves down the line zz' . At point g only γ will be present and the microstructure having only γ grains.
- Upon cooling into the $\gamma+\text{Fe}_3\text{C}$ phase field – say to the cementite phase will begin to form along the grain boundaries, similar to the α phase in point d .

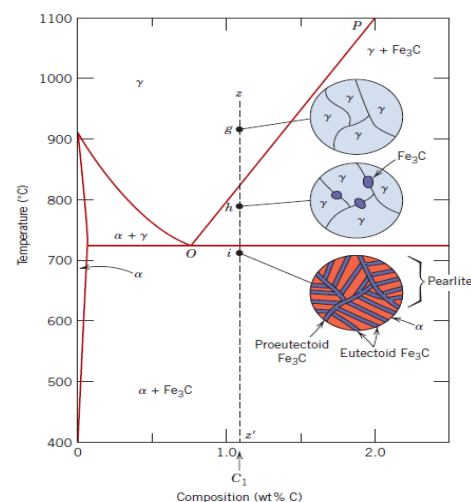

upon
the γ phase
gamma

point h –
initial γ
this

cementite is called *proeutectoid cementite* that which forms before the eutectoid reaction.

- As the temperature is lowered through the eutectoid to point I, all remaining austenite of eutectoid composition is converted into pearlite; thus the resulting microstructure consists of pearlite and proeutectoid cementite as microconstituents.

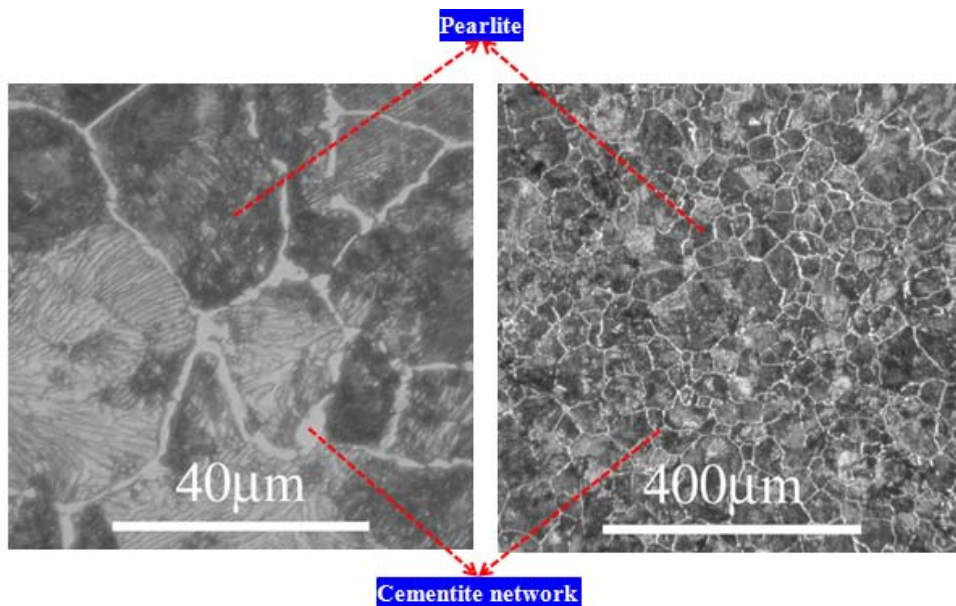

Application of Lever rule in Fe-Fe₃C phase diagram

Solved Example For a 99.6 wt% Fe-0.40 wt% C at a temperature just below the eutectoid, determine the following:

- The amount of Fe₃C, ferrite (α) and pearlite
- The amount of pearlite and proeutectoid ferrite (α)

a) The amount of Fe₃C and ferrite (α)

$$\text{Percentage of Fe}_3\text{C} = \frac{0.4 - 0.025}{6.67 - 0.025} * 100$$

Percentage of Fe₃C in 0.4 %C steel is 5.64 %

Percentage of Ferrite (α) in 0.4 %C steel = (100- 5.64)%

Percentage of ferrite in 0.4 %C steel = 94.36%

or

$$\text{Percentage of ferrite} = \frac{6.67 - 0.4}{6.67 - 0.025} * 100 = 94.36\%$$

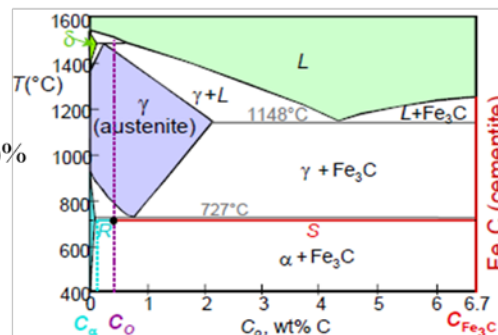
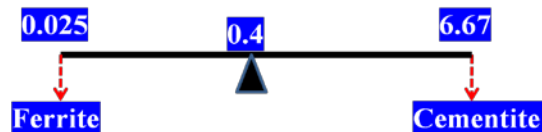

b) Phase fraction of pearlite and proeutectoid ferrite (α)

$$\text{Percentage of pearlite} = \frac{0.4 - 0.025}{0.8 - 0.025} * 100$$

Percentage of pearlite = 48 %

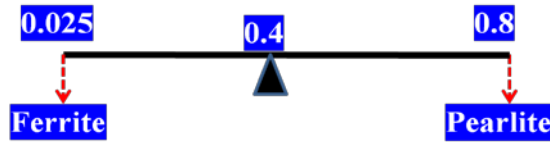

Percentage of proeutectoid ferrite (α) in 0.4 %C steel = (100- 48)%

Percentage of proeutectoid ferrite (α) = 52 %

or

$$\text{Percentage of proeutectoid ferrite} = \frac{0.8 - 0.4}{0.8 - 0.025} * 100 = 52\%$$

Critical temperature lines

- In general, A_0 – Subcritical temperature, A_1 - lower critical temperature, A_3 - upper critical temperature, A_4 – Eutectic temperature, A_5 – Peritectic temperature and A_{cm} - γ/γ +cementite phase field boundary.
- While heating we denoted as Ac_1 , Ac_2 , Ac_3 etc., ‘c’ stands for *chauffage* (French word), which means heating and while cooling we denoted as Ar_1 , Ar_2 , Ar_3 etc., ‘r’ stands for *refroidissement*, (French word) which means cooling.

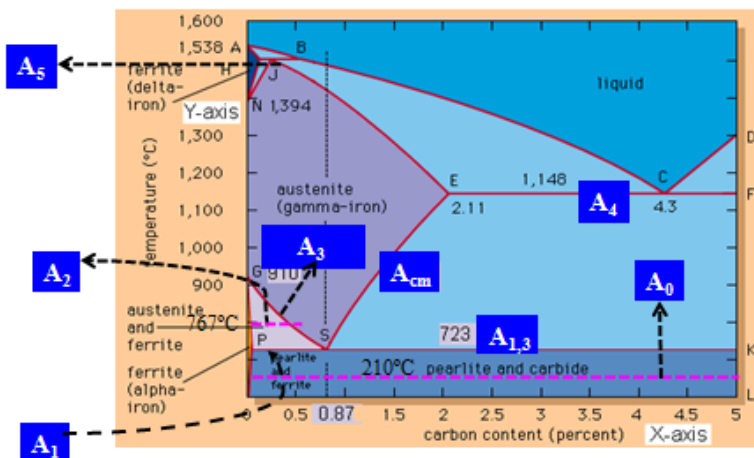

Martensitic Transformations

- Under slow cooling rates, the carbon atoms are able to diffuse out of the austenite structure and it leads to gamma to alpha transformation . This process involves nucleation and growth and it is time dependent.
- With a still further increase in cooling rate, insufficient time is allowed for the carbon to diffuse out of solution, and although some movement of the iron atoms takes place, the structure cannot become B.C.C. while the carbon is trapped in solution.
- *The resultant structure is called Martensite, is a supersaturated solid solution of carbon trapped in a body-centered tetragonal structure and it is a metastable phase.*
- The highly distorted lattice structure is the prime reason for the high hardness of martensite.
- After drastic cooling, martensite appears microscopically as a white needlelike or acicular structure or lenticular, sometimes described as pile of straw.
- Shape of the Martensite formed →Lenticular (or thin parallel plates)
- Associated with shape change (shear)
- This condition requires:
 - Bain distortion → Expansion or contraction of the lattice along certain crystallographic directions leading to homogenous pure dilation
 - Secondary Shear Distortion →Slip or twinning
 - Rigid Body rotation

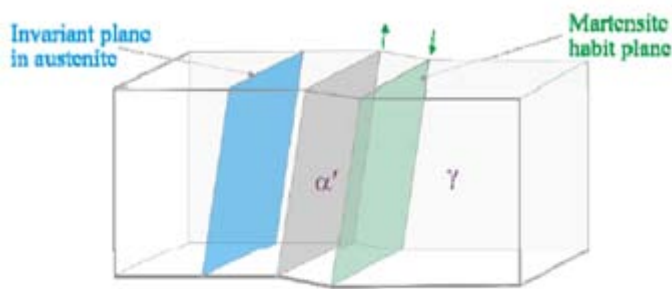
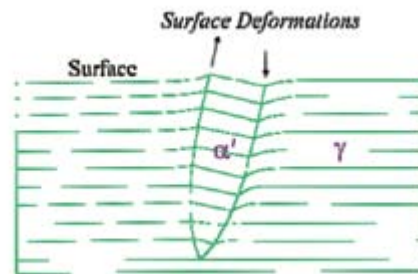
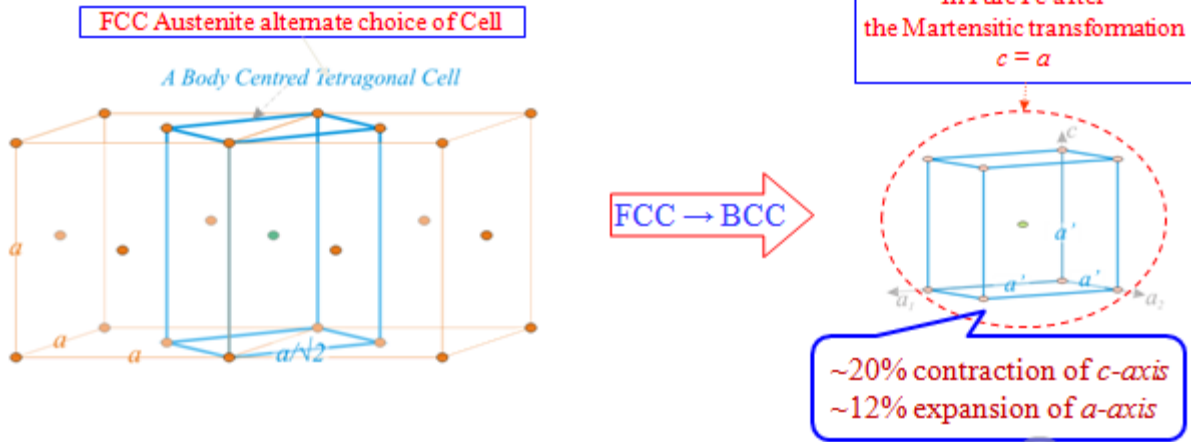

Illustration of the coherence of the martensitic plate with the surrounding austenite



- Martensitic transformation can be understood by first considering an alternate unit cell for the Austenite phase as shown in the figure below.
- If there is no carbon in the Austenite (as in the schematic below), then the Martensitic transformation can be understood as a ~20% contraction along the c-axis and a ~12% expansion of the a-axis → accompanied by no volume change and the resultant structure has a BCC lattice (the usual BCC-Fe) → c/a ratio of 1.0.



- In the presence of Carbon in the octahedral voids of CCP (FCC) γ -Fe (as in the schematic below)

below) \rightarrow the contraction along the c -axis is impeded by the carbon atoms. (Note that only a fraction of the octahedral voids are filled with carbon as the percentage of C in Fe is small).

- However the a_1 and a_2 axis can expand freely. This leads to a product with c/a ratio (c'/a') > 1
- In this case there is an overall increase in volume of $\sim 4.3\%$ (depends on the carbon content) \rightarrow the Bain distortion.

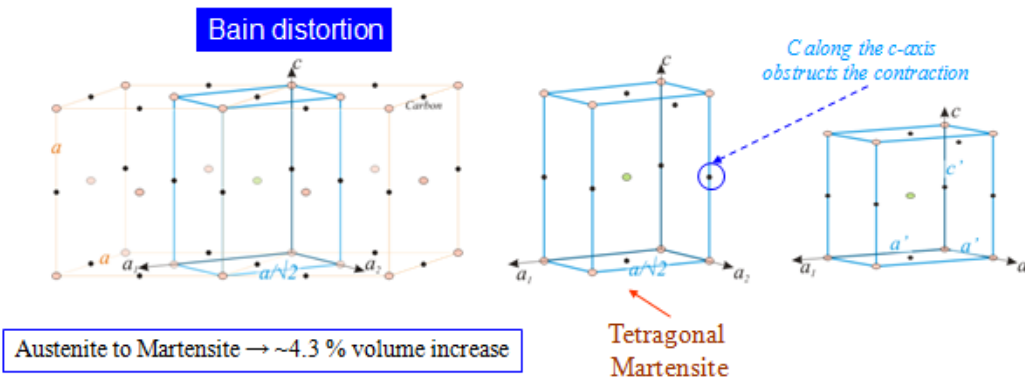

- The Martensitic transformation occurs without composition change
- The transformation occurs by shear without need for diffusion and is called diffusion less transformation
- The atomic movements (*shearing*) required are only a fraction of the inter atomic spacing
- The shear changes the shape of the transforming region
 - \rightarrow results in considerable amount of shear energy
 - \rightarrow plate-like shape of Martensite
- The amount of martensite formed is a function of the temperature to which the sample is quenched and not of time
- Hardness of martensite is a function of the carbon content
 - \rightarrow but high hardness steel is very brittle as martensite is brittle

- Steel is reheated to increase its ductility
→ this process is called TEMPERING
- The martensite transformation, for many years, was believed to be unique for steel. However, in recent years, this martensite type of transformation has been found in a number of other alloy systems, such as iron-nickel, copper-zinc, and copper-aluminum.
- The basic purpose of hardening is to produce a fully martensitic structure, and the minimum cooling rate (per second) that will avoid the formation of any of the softer products of transformation is known as the *critical cooling rate*.
- The critical cooling rate, determined by chemical composition and austenitic grain size, is an important property of a steel since it indicates how fast a steel must be cooled in order to form only martensite

Time-Temperature-Transformation (TTT) Diagrams

- Davenport and Bain were the first to develop the TTT diagram of eutectoid steel. They determined pearlite and bainite portions whereas Cohen later modified and included M_S and M_F temperatures for martensite.
- There are number of methods used to determine TTT diagrams. The most popular method is salt bath techniques combined with metallography and hardness measurement with addition of this we have other techniques like dilatometry, electrical resistivity method, magnetic permeability, *in situ* diffraction techniques (X-ray, neutron), acoustic emission, thermal measurement techniques, density measurement techniques and thermodynamic predictions.
- TTT diagrams, also called as Isothermal (*temperature constant*) Transformation diagrams.
- TTT diagrams give the kinetics of isothermal transformations.
- For every composition of steel we should draw a different TTT diagram.
- For the determination of isothermal transformation (or) TTT diagrams, we consider *molten salt bath technique* combined with metallography and hardness measurements.
- In *molten salt bath technique* two salt baths and one water bath are used. Salt bath I is maintained at austenising temperature (780°C for eutectoid steel). Salt bath II is maintained at specified temperature at which transformation is to be determined (below A_{e1}), typically $700\text{-}250^\circ\text{C}$ for eutectoid steel. Bath III which is a cold water bath is maintained at room temperature.
- In bath I number of samples are austenite at $A_1+20\text{-}40^\circ\text{C}$ for eutectoid, $A_3+20\text{-}40^\circ\text{C}$ for hypo-eutectoid steel and $A_{Cm}+20\text{-}40^\circ\text{C}$ for hyper-eutectoid steels for about an hour.
- Then samples are removed from bath I and put in bath II and each one is kept for different specified period of time say $t_1, t_2, t_3, t_4, \dots, t_n$ etc. After specified times, the samples are removed and quenched in cold water. The microstructure of each sample is studied using metallographic techniques. The type, as well as quantity of phases, is determined on each sample.

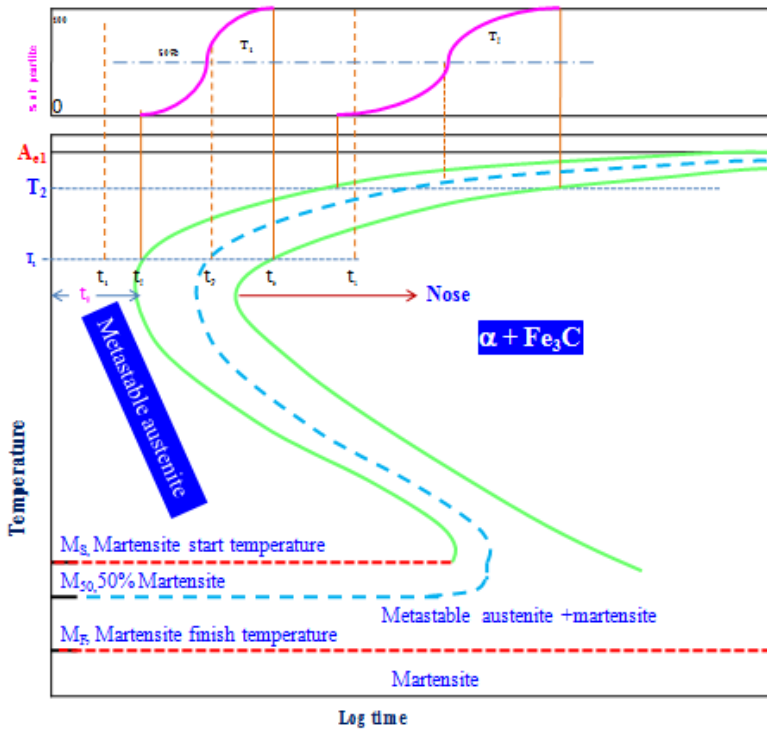

✓ At T_1 , incubation period for pearlite= t_2 , Pearlite finish time= t_4

✓ Minimum incubation period t_0 at the nose of the TTT diagram,

Important points to be noted:

✓ The x-axis is log scale. 'Nose' of the 'C' curve is in ~sec and just below T_F transformation times may be ~day.

✓ The starting phase (left of the C curve) has to γ .

✓ To the right of finish C curve is $(\gamma + \text{Fe}_3\text{C})$ phase field. This phase field has more labels included.

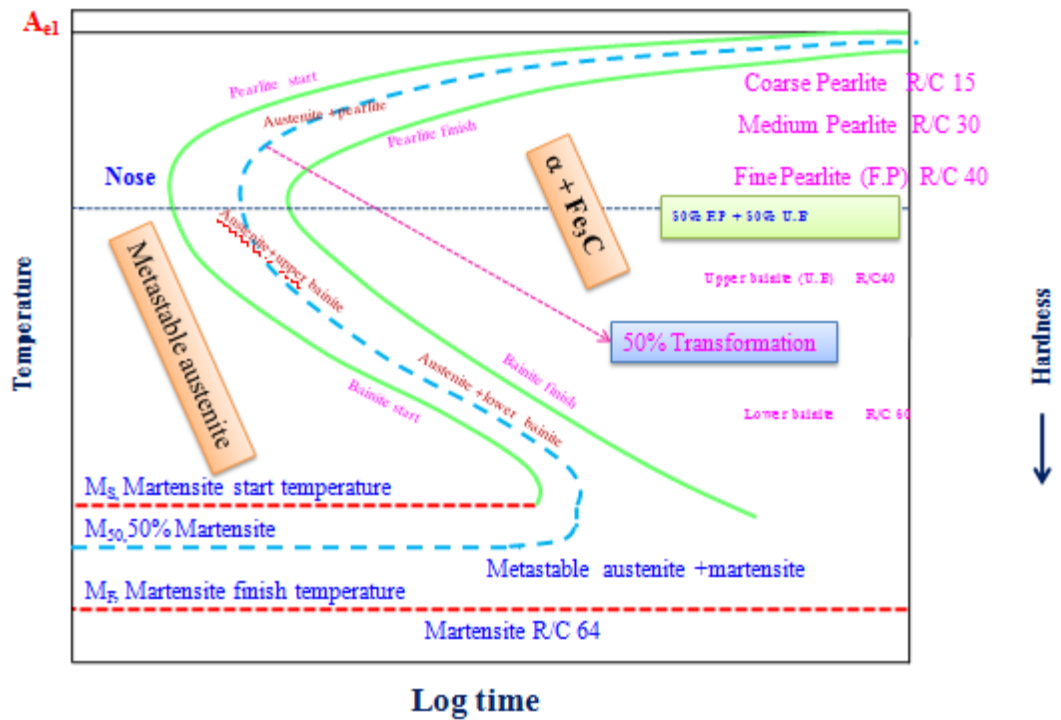

- ❑ As pointed out before one of the important utilities of the TTT diagrams comes from the overlay of micro-constituents (microstructures) on the diagram.
- ❑ Depending on the T, the $(\gamma + \text{Fe}_3\text{C})$ phase field is labeled with micro-constituents like Pearlite, Bainite.

- ❑ The time taken to 1% transformation to, say pearlite or bainite is considered as transformation start time and for 99% transformation represents transformation finish.
- ❑ We had seen that TTT diagrams are drawn by instantaneous quench to a temperature followed by isothermal hold.
- ❑ Suppose we quench below ($\sim 225^\circ\text{C}$, below the temperature marked M_s), then Austenite transforms via a diffusionless transformation (*involving shear*) to a (*hard*) phase known as Martensite. Below a temperature marked M_f this transformation to Martensite is complete. Once γ is exhausted it cannot transform to ($\gamma + \text{Fe}_3\text{C}$).
- ❑ Hence, we have a new phase field for Martensite. The fraction of Martensite formed is not a function of the time of hold, but the temperature to which we quench (between M_s and M_f).
- ❑ Strictly speaking cooling curves (including finite quenching rates) should not be overlaid on TTT diagrams (*remember that TTT diagrams are drawn for isothermal holds!*).

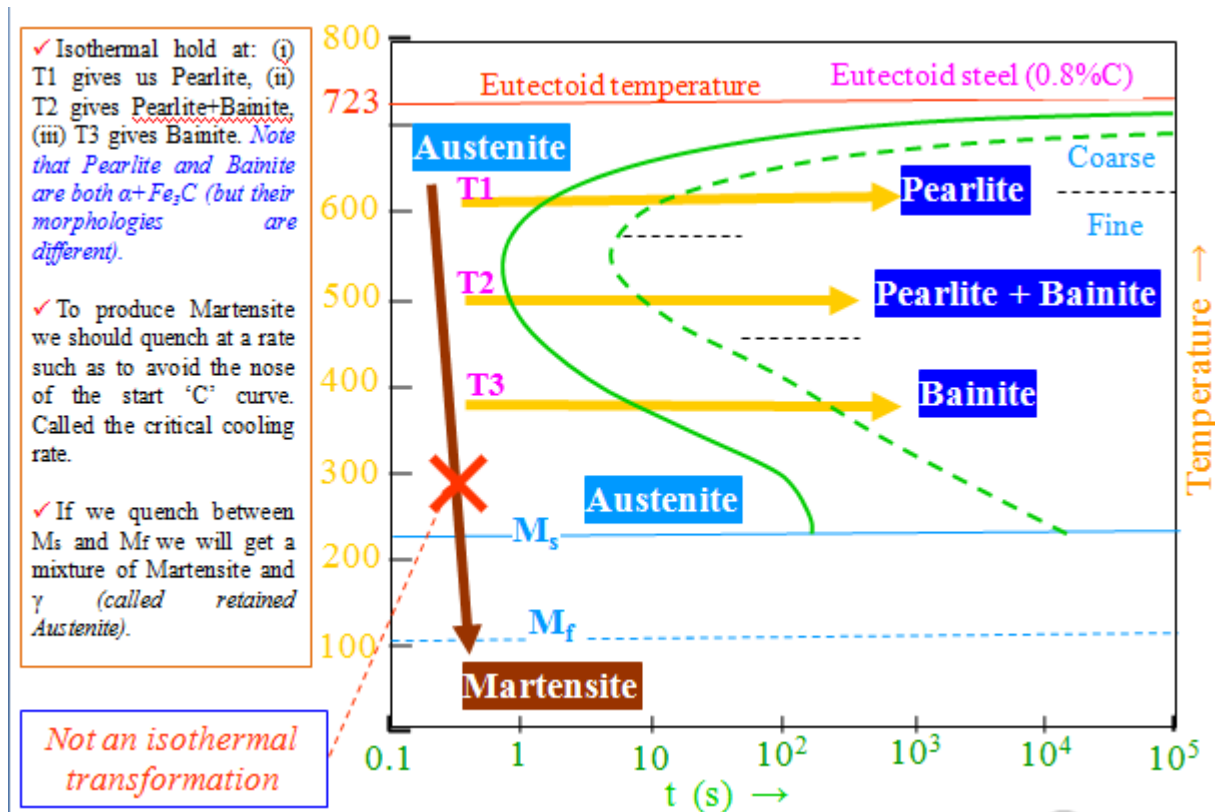

TTT diagram for Hypo eutectoid steel

- ❑ In hypo- (and hyper-) eutectoid steels (say C_1) there is one more branch to the 'C' curve-NP marked in red).

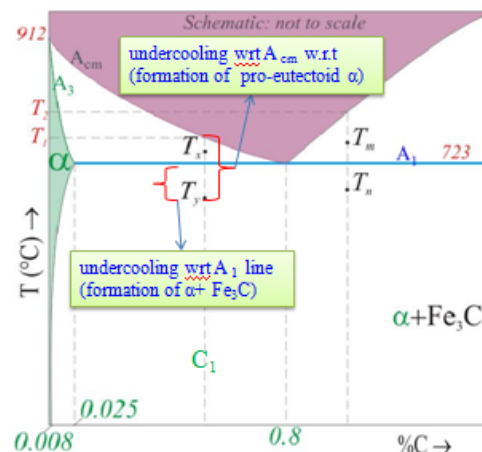

composition (next slide:

- ❑ The part of the curve lying between T_1 and T_E (marked in fig : next slide) is clear, because in this range of temperatures we expect only pro-eutectoid α to form and the final microstructure will consist of α and γ . (E.g. if we cool to T_x and hold).
- ❑ The part of the curve below T_E is a bit of a ‘mystery’ (since we are instantaneously cooling to below T_E , we should get a mix of $\alpha + Fe_3C$ what is the meaning of a ‘pro’-eutectoid phase in a TTT diagram? (remember ‘pro-’ implies ‘pre-’)
- ❑ Suppose we quench instantaneously an hypo-eutectoid composition C_1 to T_x we should expect the formation of $\alpha + Fe_3C$ (and not pro-eutectoid α first).
- ❑ The reason we see the formation of pro-eutectoid α first is that the undercooling w.r.t to A_{cm} is more than the undercooling w.r.t to A_1 . Hence, there is a higher propensity for the formation of pro-eutectoid α .

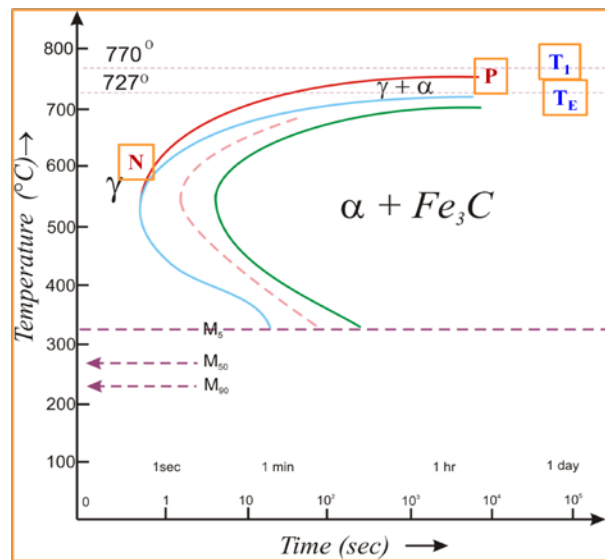

TTT diagram for Hyper eutectoid steel

- ❑ Similar to the hypo-eutectoid case, hyper-eutectoid compositions C_2 have a $\gamma + Fe_3C$ branch.
- ❑ For a temperature between T_2 and T_E (say T_m (not melting point- just a label)) we land up with $\gamma + Fe_3C$.
- ❑ For a temperature below T_E (but above the nose of the ‘C’ curve) (say T_n), first we have the formation of pro-eutectoid Fe_3C followed by the formation of eutectoid $\gamma + Fe_3C$.

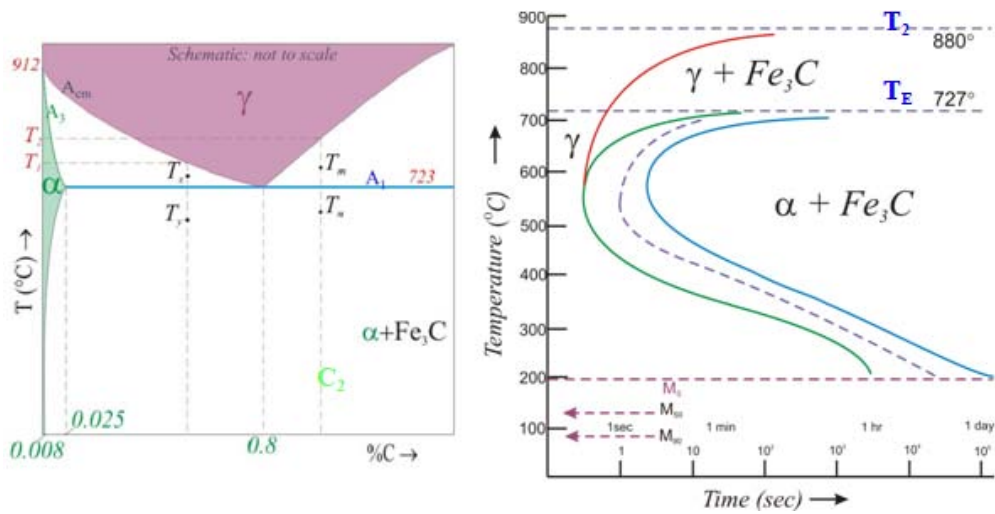

Transformation to Pearlite

- The transformation product above the nose region is pearlite. The pearlite microstructure is the characteristic lamellar structure of alternate layers of ferrite and cementite.
- As the transformation temperature decreases, the characteristic lamellar structure is maintained, but the spacing between the ferrite and carbide layers becomes increasingly smaller until the separate layers cannot be resolved with the light microscope.
- As the temperature of transformation and the fineness of the pearlite decreases, it is apparent that the hardness will increase.

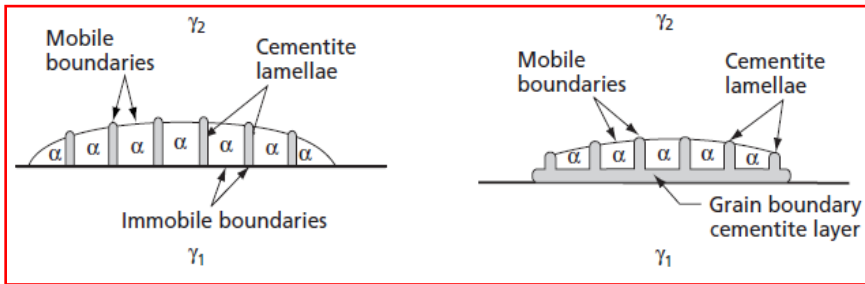

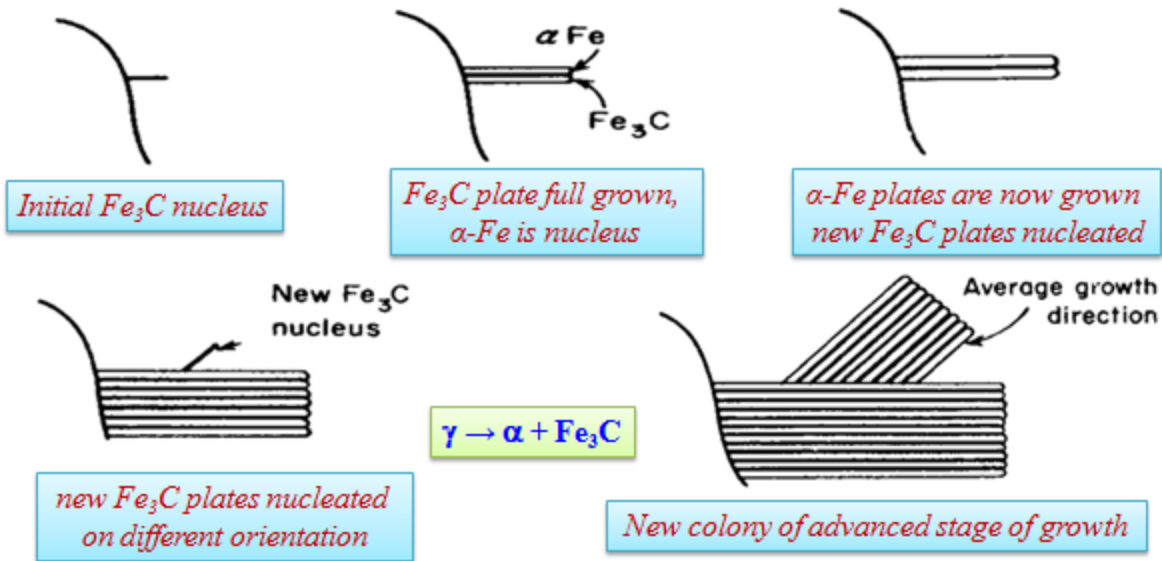

- Nucleation and growth
- Heterogeneous nucleation at grain boundaries
- Interlamellar spacing is a function of the temperature of transformation
- Lower temperature \rightarrow finer spacing \rightarrow higher hardness

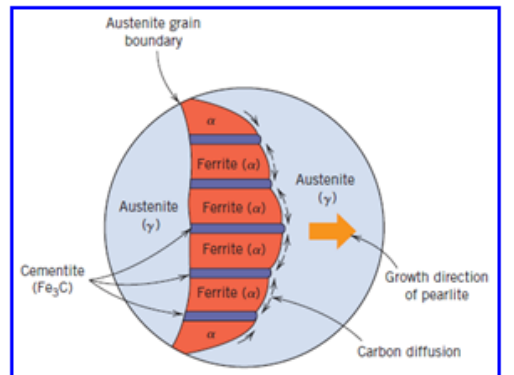
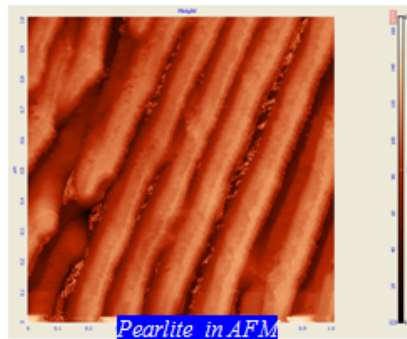

Schematic representation of the formation of pearlite from austenite; direction of carbon diffusion indicated by arrows

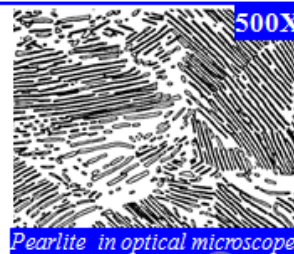

Transformation to Bainite

- In between the nose region of approximately 510°C and the M_s temperature, a new, dark-etching aggregate of ferrite and cementite appears. This structure, named after E.C.Bain, is called bainite.
- At upper temperatures of the transformation range, it resembles pearlite and is known as upper or feathery bainite. At low temperatures it appears as a black needlelike structure resembling martensite and is known as lower or acicular bainite.

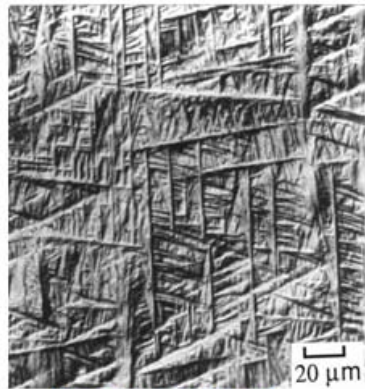

Upper or Feathery bainite

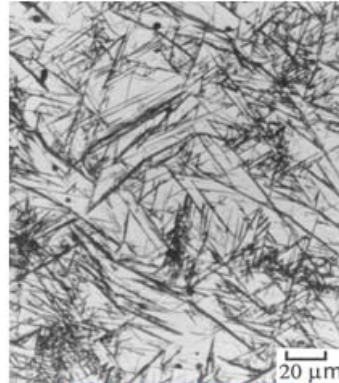

Lower or Acicular bainite

- ❑ Pearlite is nucleated by a carbide crystal, bainite is nucleated by a ferrite crystal, and this results in a different growth pattern.
- ❑ Acicular, accompanied by surface distortions
- ❑ ** Lower temperature → carbide could be ϵ carbide (hexagonal structure, 8.4% C)
- ❑ Bainite plates have irrational habit planes
- ❑ Ferrite in Bainite plates possess different orientation relationship relative to the parent Austenite than does the Ferrite in Pearlite



Bainite formed at 348°C



Bainite formed at 278°C

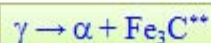

Continuous Cooling Transformation diagrams

- ❑ The TTT diagrams are also called Isothermal Transformation Diagrams, because the transformation times are representative of isothermal hold treatment (following a instantaneous quench).

- ❑ In practical situations we follow heat treatments (T-t procedures/cycles) in which (typically) there are steps involving cooling of the sample. The cooling rate may or may not be constant. The rate of cooling may be slow (as in a furnace which has been switch off) or rapid (like quenching in water).
- ❑ Hence, in terms of practical utility TTT curves have a limitation and we need to draw separate diagrams called Continuous Cooling Transformation diagrams (CCT), wherein transformation times (also: products & microstructure) are noted using constant rate cooling treatments. A diagram drawn for a given cooling rate (dT/dt) is typically used for a range of cooling rates (thus avoiding the need for a separate diagram for every cooling rate).
- ❑ However, often TTT diagrams are used for constant cooling rate experiments- keeping in view the assumptions & approximations involved.
- ❑ The CCT diagram for eutectoid is considered next.
- ❑ *Important difference between the & TTT transformations is that in the case Bainite cannot form.*

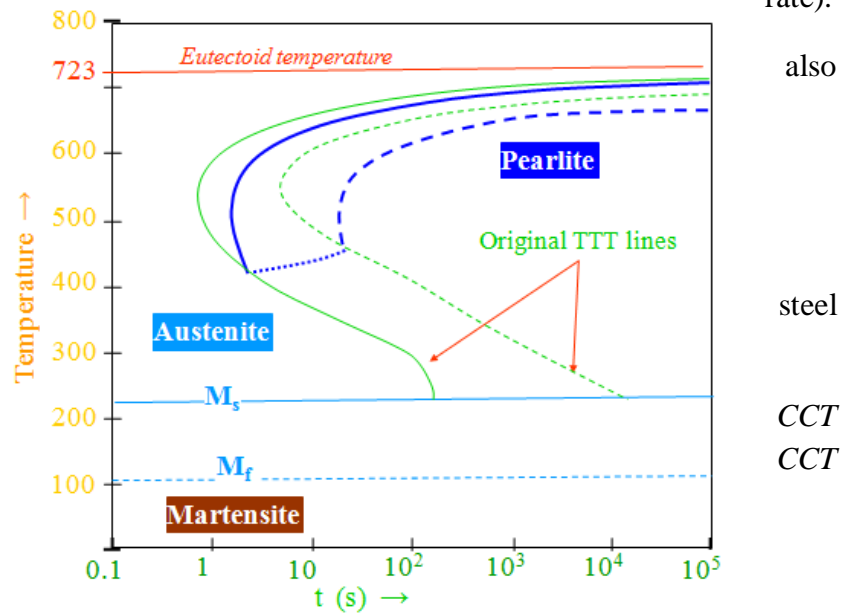

4.1 Heat Treatment

A heat treatment can be defined as the process to subject a material to a predetermined time-temperature profile in the solid state to achieve desired combination of properties through alteration of microstructural features, such as, grain size, phase distribution, etc.

General heat treatment processes

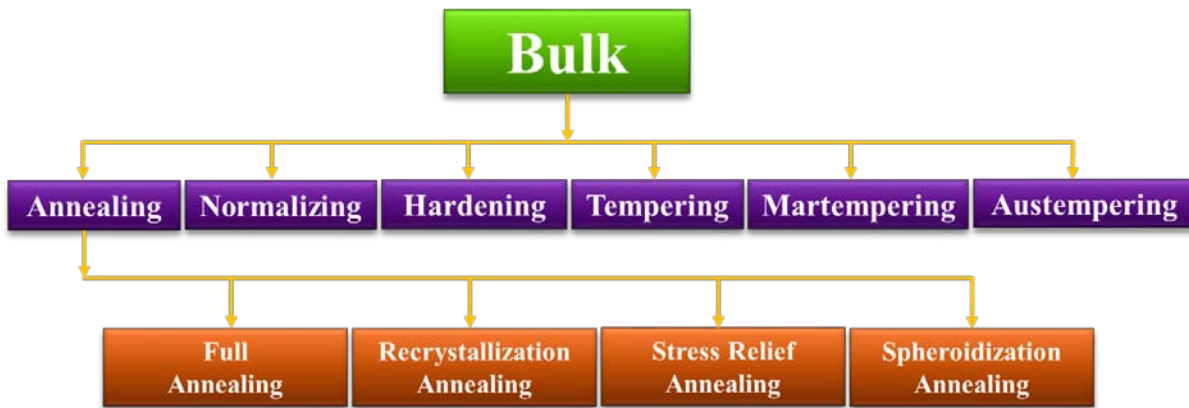

Annealing

Annealing cycles are varied according to the temperature and the method of cooling used. Annealing temperatures may be classified as:

- Subcritical annealing (below the lower critical temperature, A_1)
- Intercritical annealing (above A_1 but below the upper critical temperature, A_3 in hypoeutectoid steels, or A_{cm} in hypereutectoid steels)
- Supercritical annealing to achieve full austenitization of either hypo- or hyper-eutectoid steels.

Some commonly used heat treatment cycle superimposed on Fe-C equilibrium diagram is shown in Fig. 1.

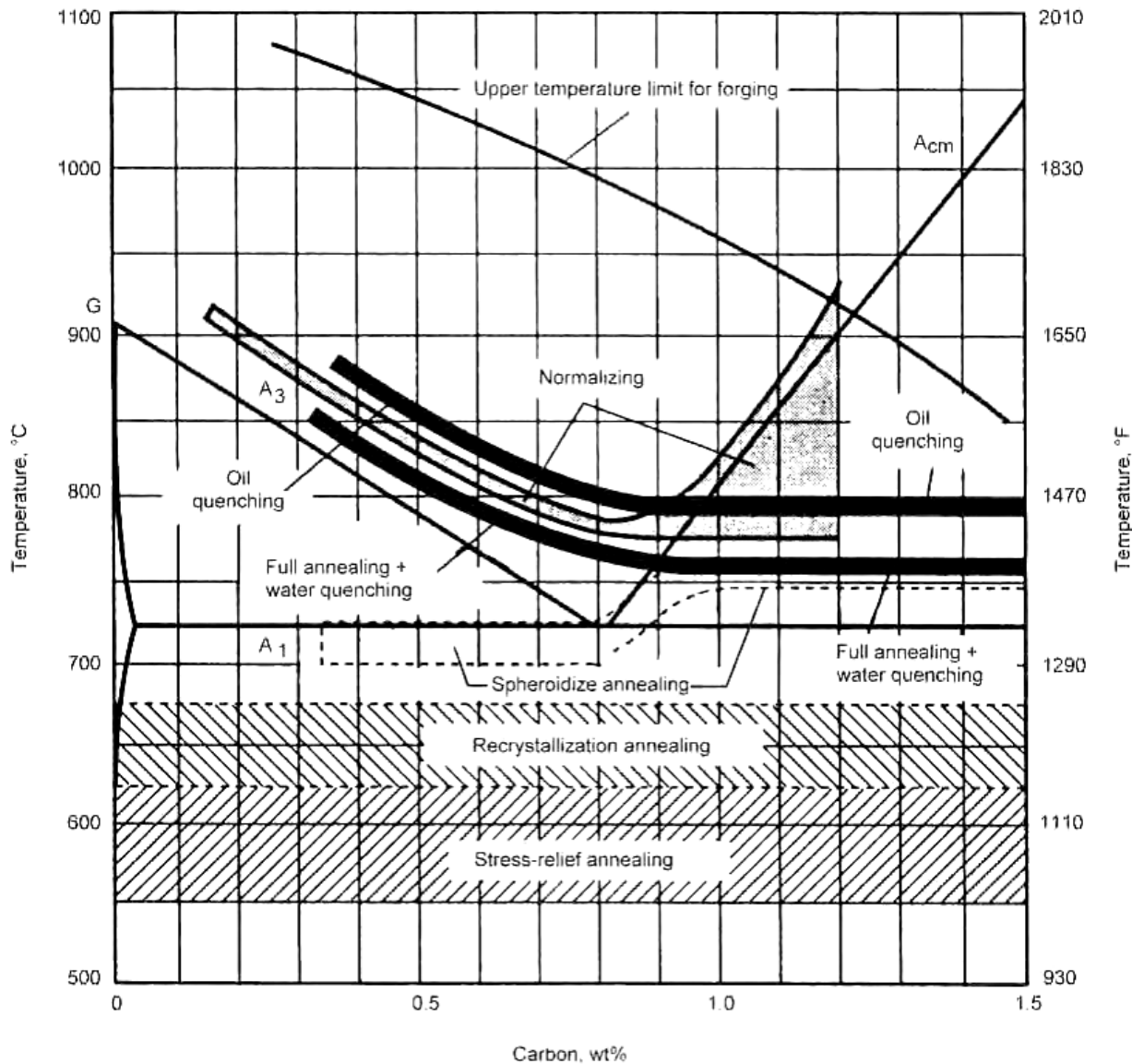

Fig.4.1 Approximate temperature ranges for various heat treatments applied to steels.

Full Annealing

- The temperatures for full annealing are typically 50°C (90°F) above the upper critical temperature (A3) for hypoeutectic steels and the lower critical temperature (A1) for hypereutectoid steels.
- It is referred to as *full annealing* because it achieves full austenitization of hypoeutectoid steels.
- The indicated temperatures for full annealing are a supercritical anneal for hypoeutectoid steels, but are in the range of an intercritical anneal for hypereutectoid steels.
- Full annealing produces a microstructure that is softer and more amenable to other processing such as forming or machining.
- In addition, stainless and high-alloy steels may be austenitized (fully annealed) and quenched to minimize the presence of grain boundary carbides or to improve the ferrite distribution.
- The temperatures for full annealing are in approximately the same range of austenitization temperatures for water quenching (Fig. 4.1) but are below austenitization temperatures for either normalizing or hardening by oil quenching.

Recrystallization Annealing

- When cold worked metals are heated to a sufficiently high temperature, the badly deformed cold worked grains are replaced by new strain-free grains.
- This process is referred to as recrystallization, which is distinct from the recovery process during stress relief. At a constant temperature, recovery starts rapidly and then decreases with time. On the other hand, recrystallization, which is a nucleation and growth process, starts slowly and then builds up to a maximum rate before rapidly leveling off. Recrystallization annealing of steel is done at subcritical temperatures (Fig. 4.1).
- Recrystallization annealing of cold worked metal can produce a new grain structure without inducing a phase change. The *recrystallization temperature* is often defined as the temperature required for the microstructure to undergo 50% recrystallization in 30 min, and for complete recrystallization in approximately one hour.
- Although there is a trade-off between time and temperature, temperature is a much more dominant variable than time. Recrystallization occurs more rapidly at higher temperatures. For most kinetic processes, increasing the temperature by approximately 11°C (20°F) doubles the reaction rate. Once recrystallization is complete, further heating causes grain growth to occur. The recrystallized grain size is dependent on both the recrystallization time and temperature, particularly the temperature. Higher temperatures tend to promote larger grain sizes.
- The temperature required for recrystallization is not exact—it depends on the composition of the alloy and in particular on the amount of cold work performed. Therefore, recovery may affect the recrystallization temperature, because the tendency toward recrystallization is lowered when appreciable recovery has occurred; that is, a higher temperature may then be required to cause recrystallization. In addition, grain size affects the nucleation rate and the recrystallization temperature. For equal amounts of cold work, a lower recrystallization temperature and shorter recrystallization time occurs for fine-grained metal than in coarse grained metal.

Stress Relief Annealing

- Annealing at subcritical temperatures (below A_{c1}) includes three different temperature regions (Fig. 4.1). The first is the temperature range for stress-relief annealing.
- Annealing involves uniform heating of a structure, or portion thereof, and holding at this temperature for a predetermined period of time, followed by uniform cooling. Stress relief temperatures are sufficiently high to help activate the microstructural process of *recovery*, such that stored internal strain energy is relieved by rearrangement of dislocations into lower-energy configurations without any change in the shape and orientation of grains.
- Stress-relief heat treating is used to relieve stresses from cold working. Care must be taken to ensure uniform cooling, particularly when a component is composed of variable section sizes. If the rate of cooling is not constant and uniform, new residual stresses can result that are equal to or greater than those that the heat-treating process was intended to relieve.

- Stress-relief heat treating can reduce distortion and high stresses from welding that can affect service performance. The presence of residual stresses can lead to stress-corrosion cracking (SCC) near welds and in regions of a component that has been cold strained during processing.

Spheroidizing

- Depending on the time-temperature exposure of a steel, the cementite carbides in a steel can form different morphologies, such as the lamellar cementite of pearlite, or a network of cementite along prior austenite grain boundaries in a hypereutectoid steel.
- The shape and distribution of the carbides can be modified by heat treatment, and spheroidization treatments are used to produce carbides with a more spherical morphology.
- Because spherical shapes have lower surface energy than angular shapes, the lamellar shape of cementite in pearlite changes morphology to form spheroids. Portions of the lamellae “pinch off” (dissolve) to form a spheroid from the remaining portions of lamellae. This process can occur over a long period of time, or it can be accelerated by heat treatment. Depending on the steel, spheroidized carbides can lead to improved machinability, toughness, and formability.
- In hypoeutectoid steels, prolonged holding at a temperature just below Ae_1 accelerates the process of spheroidization. The process may take several hours. To improve on kinetics for full spheroidization, some treatments involve heating and cooling alternately between temperatures that are just above Ac_1 and just below Ar_1 .
- In low-carbon steels, the typical purpose of spheroidizing is to improve the cold formability of steels. The formability of steel is altered significantly depending on whether carbides are spheroids or present as lamellae in pearlite. Low-carbon steels are seldom spheroidized for machining, because in the spheroidized condition they are excessively soft and “gummy,” cutting with long, tough chips.
- In hypereutectoid steels ($C > 0.77\%$) and tool steels, spheroidization is done to improve machinability and improve toughness. Heating of hypereutectoid steels above Ac_1 is done to create dispersed cementite particulates. Heating to dissolve the carbide prevents reformation of a carbide network. If a temperature slightly above Ac_1 is to be used, good loading characteristics and accurate temperature controls are required for proper results; otherwise, it is conceivable that Ac_1 may not be reached and that austenitization may not occur.

Normalizing

- Steel is normalized to refine grain size, make its structure more uniform, make it more responsive to hardening, and to improve machinability.

- When steel is heated to a high temperature, the carbon can readily diffuse, resulting in a reasonably uniform composition from one area to the next. The steel is then more homogeneous and will respond to the heat treatment more uniformly.
- Normalizing is an austenitizing heating cycle followed by cooling in still or slightly agitated air. Typically, the temperatures for normalizing (Fig. 4.1) are approximately 55°C (100°F) above the upper critical line (that is, above A_{c3} for hypoeutectoid steels and above A_{cm} for hypereutectoid steels).
- To be properly classed as a normalizing treatment, the heating portion of the process must produce a homogeneous austenitic phase prior to cooling. Fig. 4.2 compares the time-temperature cycle of normalizing to that of full annealing.

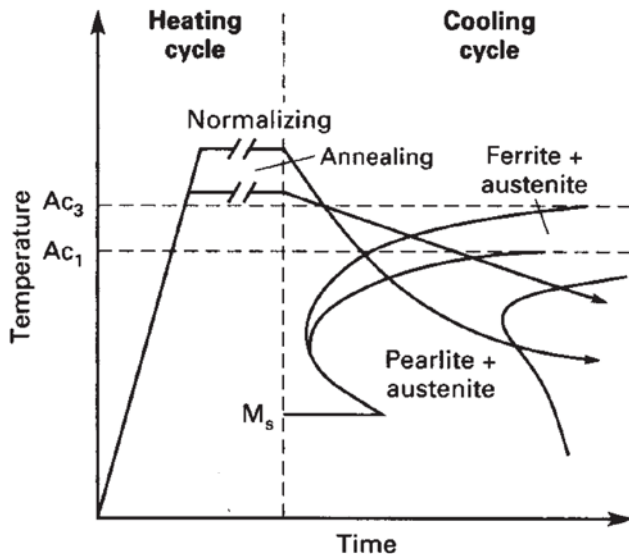

Fig. 4.2 Comparison of normalizing and full annealing heat treatment cycle

Hardening

- The maximum hardness of any steel is associated with a fully martensitic structure. This microstructure can be produced only if the cooling rate applied is higher than the critical cooling rate for the corresponding steel.
- Hardenability is defined as the “susceptibility to hardening by rapid cooling”, or as “the property, in ferrous alloys, that determines the depth and distribution of hardness produced by quenching”. Both of these definitions emphasize hardness. As discussed previously, the source of hardening is the formation and presence of martensite, and therefore a third definition of hardenability, “the capacity of a steel to transform partially or completely from austenite to some percentage of martensite at a given depth when cooled under some given conditions,” more accurately describes the physical process underlying hardening.

Severity of Quench

- The effectiveness of a given quenching medium is ranked by a parameter referred to as its “severity of quench.” This measure of cooling or quenching power is identified by the letter “H” and is determined experimentally by quenching a series of round bars of a given steel.
- Table I lists H values for a number of commonly used quenches. Note that apart from the nature of the quenching medium, the vigorousness of the shake determines the severity of the quench. When a hot solid is put into a liquid medium, gas bubbles form on the surface of the solid (interface with medium). As gas has a poor conductivity the quenching rate is reduced. Providing agitation (shaking the solid in the liquid) helps in bringing the liquid medium in direct contact with the solid; thus improving the heat transfer (and the cooling rate).

Table I. Severity of quench (H) for various quenching media

	Air	Oil	Water	Brine
No circulation of fluid or agitation of piece	0.02	0.25–0.30	0.9–1.0	2
Mild circulation (or agitation)	...	0.30–0.35	1.0–1.1	2–2.2
Moderate circulation	...	0.35–0.40	1.2–1.3	...
Good circulation	...	0.4–0.5	1.4–1.5	...
Strong circulation	0.05	0.5–0.8	1.6–2.0	...
Violent circulation	...	0.8–1.1	4	5

Source: Ref 16.16, 16.22

Jominy test for Hardenability

- Fig. 4.3 shows the shape and dimensions of a Jominy specimen and the fixture for supporting the specimen in a quenching system.
- The specimen is cooled at one end by a column of water; thus, the entire specimen experiences a range of cooling rates between those associated with water and air cooling.
- After quenching, parallel flats are ground on opposite sides of the specimen, and hardness readings are taken every 1/16 in. from the quenched end and plotted as shown in Fig. 4.4.
- Hardenability differences between different grades of steels can be readily compared if Jominy curves are available. For example, Fig. 4.5 shows hardenability differences between different grades of alloy steels containing 0.5% C. Higher hardness persists to greater distances from the quenched end in the more hardenable steels.

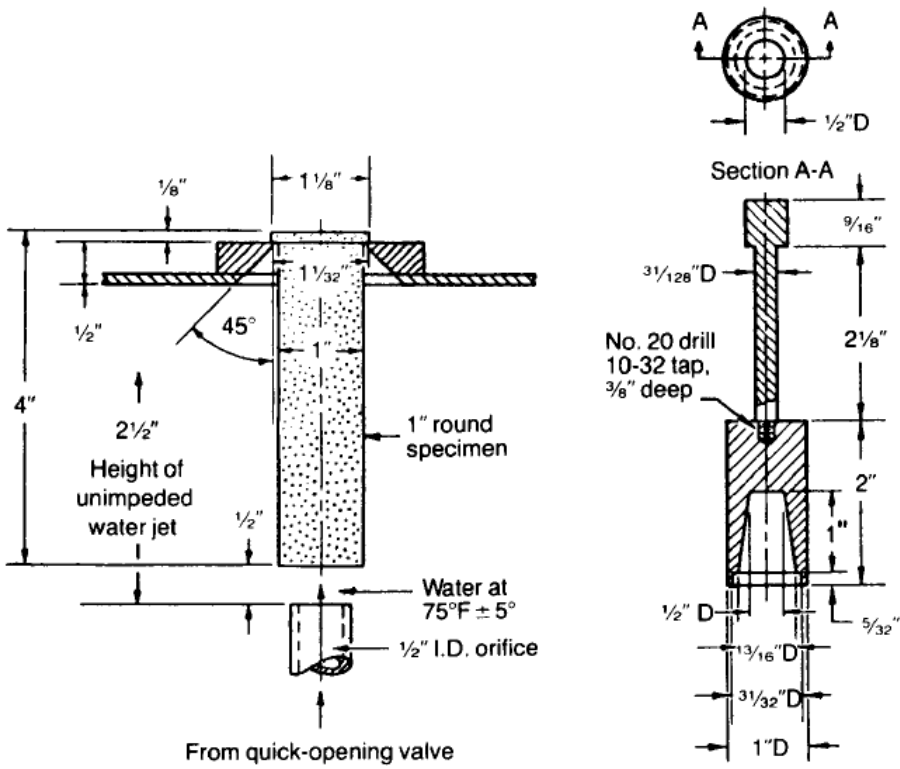

Fig. 4.3 Jominy-Boegehold specimen for end-quench test for hardenability.

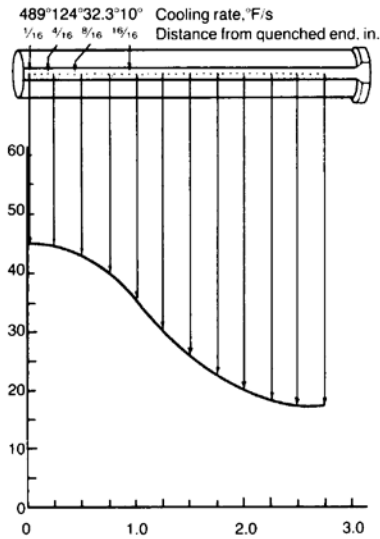

Fig. 4.4 Method of plotting hardness data from an end-quenched Jominy specimen.

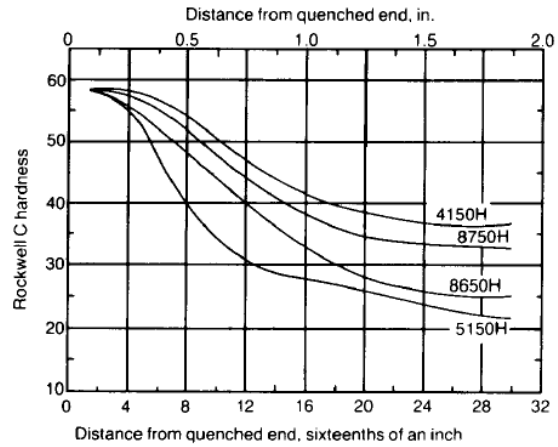

Fig.4.5 Results of end-quench tests for four different grades of alloy steels, all containing 0.5% C.

Tempering

- Martensite in steels can be a very strong and in its “as quenched” condition rather brittle. It is then necessary to modify its mechanical properties by heat treatment in the range 150–700°C. This process is called *tempering*, in which the microstructure approaches equilibrium under the influence of thermal activation.
- The general trend during the tempering of martensite therefore begins with the rejection of excess carbon to precipitate carbides but the substitutional solutes do not diffuse during this process. The end result of tempering is a dispersion of coarse carbides in a ferritic matrix which bears little resemblance to the original martensite.
- It should be borne in mind that in many steels, the martensite reaction does not go to completion on quenching, resulting in varying amounts of retained austenite which might decompose during the tempering process.
- The effect of tempering temperature on the hardness of steel is shown in Fig.4. 6.

Tempering of Plain Carbon Steels

On reheating as-quenched martensite, the tempering takes place in four distinct but overlapping stages:

Stage 1, up to 250°C: precipitation of ϵ -iron carbide; partial loss of tetragonality in martensite.

Stage 2, between 200°C and 300°C: decomposition of retained austenite.

Stage 3, between 200°C and 350°C: replacement of ϵ -iron carbide by cementite; martensite loses tetragonality.

Stage 4, above 350°C: cementite coarsens and spheroidizes; recrystallization of ferrite.

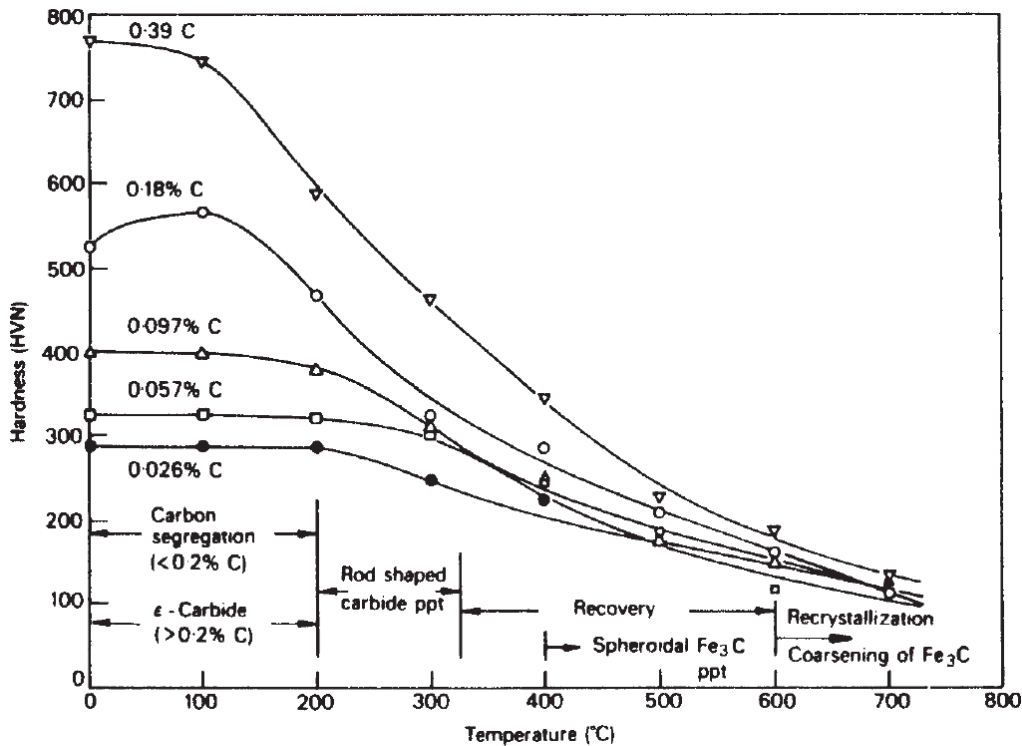

Fig. 4.6 Hardness of iron-carbon martensites tempered 1 h at 100–700°C.

Martempering

- Martempering is a heat treatment for steel involving austenitisation followed by step quenching, at a rate fast enough to avoid the formation of ferrite, pearlite or bainite to a temperature slightly above the martensite start (M_s) point. A schematic of above the process is shown in Fig.4 7.
- The advantage of martempering lies in the reduced thermal gradient between surface and center as the part is quenched to the isothermal temperature and then is air cooled to room temperature.
- Residual stresses developed during martempering are lower than those developed during conventional quenching because the greatest thermal variations occur while the steel is in the relatively plastic austenitic condition and because final transformation and thermal changes occur throughout the part at approximately the same time. Martempering also reduces or eliminate susceptibility to cracking.

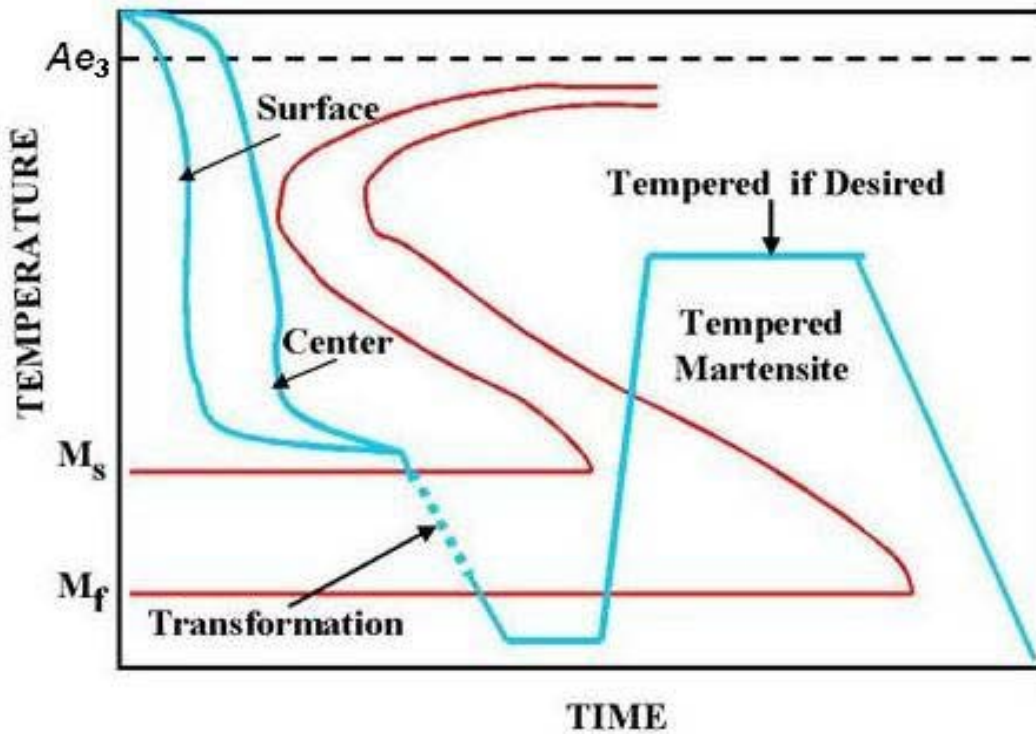

Fig. 4. 7. Schematic representation of the Martempering process.

Austempering

- Austempering process is similar to the Martempering process except that the sample after the homogenization of temperature from surface and temperature, instead of quenching, held at that temperature above M_s for sufficient time (in the bainite transformation range) to produce bainitic microstructure.
- A schematic of this process is shown in Fig. 4.8. An advantage of this process over Martempering is that the tempering can be avoided. Other advantages include, Higher ductility, Resistance to shock, Uniform hardness, Tougher and more wear resistance, Higher impact and Fatigue Strengths.

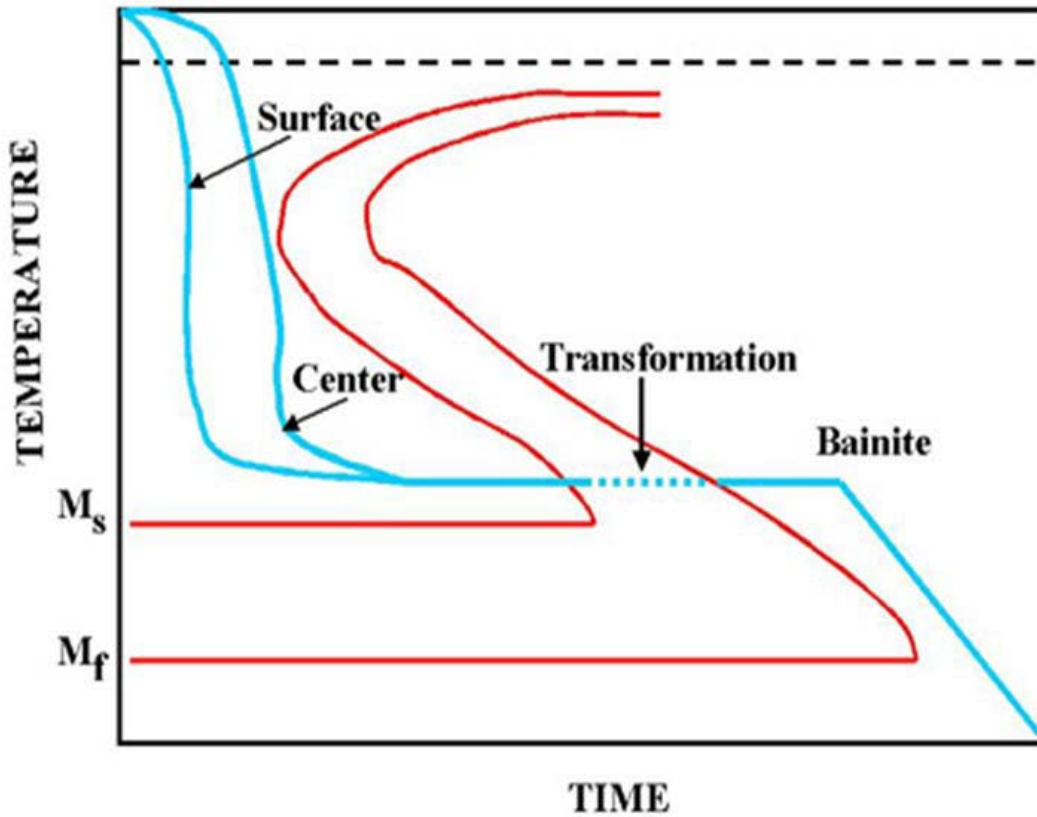
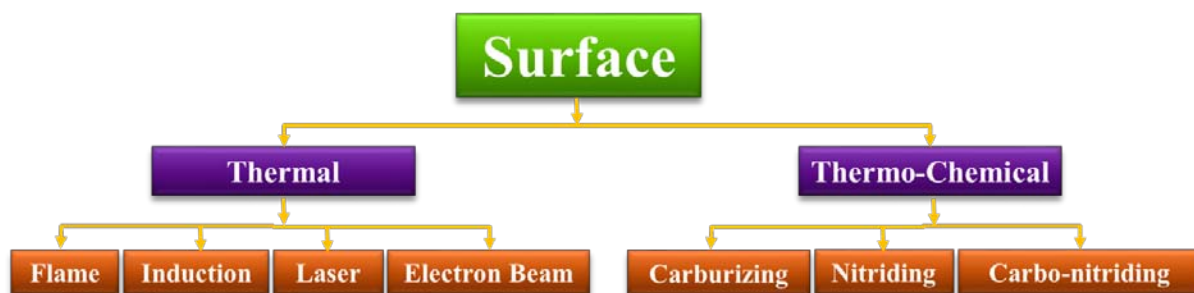

Fig. 4.8. Schematic representation of the Martempering process.

Surface Hardening

- Numerous industrial applications require a hard wear resistant surface called the *case*, and a relatively soft, tough inside called the *core*. Example: Gears
- They are two different categories. They are thermo chemical and thermo mechanical treatments. Thermo chemical treatment is related to change in chemical composition and In Thermo mechanical treatment, there is no change of chemical composition of the steel and are essentially shallow- hardening methods.
- A detailed flow chart is given below related to surface hardening treatments.



Carburizing

- Carburizing is the most widely used method of surface hardening. Here, the surface layers of a low carbon steel (<0.25) is enriched with carbon up to 0.8-1.0%. The source of carbon may be a solid medium, a liquid or a gas.
- In all cases, the carbon enters the steel at the surface and diffuses into the steel as a function of time at an elevated temperature. Carburizing is done at 920-950°C. at this temperature the following reaction takes place

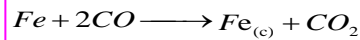

- Where $Fe_{(c)}$ represents carbon dissolved in austenite. the rate of diffusion of carbon in austenite, at a given temperature is dependent upon the diffusion coefficient and the carbon concentration gradient.
- The carburizing equation given previously, $Fe+2CO \rightarrow Fe_{(c)} + CO_2$ is reversible and may proceed to the left, removing carbon from the surface layer if the steel is heated in an atmosphere containing carbon dioxide (CO_2). This is called decarburization.
- Decarburization may be prevented by using an endothermic gas atmosphere in the furnace to protect the surface of the steel from oxygen, carbon dioxide and water vapor.
- An endothermic gas atmosphere is prepared by reacting relatively rich mixtures of air and hydrocarbon gas (usually natural gas) in an externally heated generator in the presence of a nickel catalyst.

Liquid carburizing

- Liquid carburizing is a method of case hardening steel by placing it in a bath (8% NaCN, 82% BaCl₂ and 10% NaCl) of molten cyanide so that carbon will diffuse from the bath into the metal and produce a case comparable to one resulting from pack or gas carburizing.
- Liquid carburizing may be distinguished from cyaniding by the character and composition of the case produced. The cyanide case is higher in nitrogen and lower in carbon; the reverse is true of liquid carburized cases.

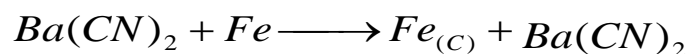
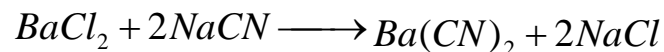

Pack carburizing

- In *pack carburizing*, the articles to be carburized are packed in a box, embedding them in a powdery mixture of 85% charcoal and 15% of energizers such as $BaCO_3$. The box is sealed with fireclay and loaded into the furnace kept at $930^\circ C$. The residual air in the box combines with carbon to produce CO. The energizer decomposes as below :

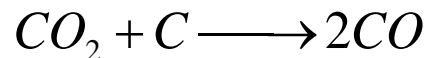
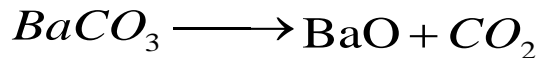

- The carbon enters the steel through the following reaction:

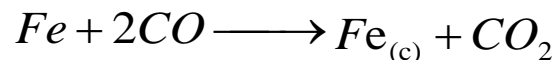

- If selective carburization is to be done, copper is electroplated to a thickness of ~ 0.05 mm in regions where carburization is not desired. Alternatively, a refractory paste of fireclay mixed with asbestos can be applied. Control of temperature and penetration depth is less in pack carburizing as compared to liquid and gas carburizing. Also, direct quench from the carburizing temperature to harden the surface is not possible.

Gas Carburizing

- The steel is heated in contact with carbon monoxide and/or a hydrocarbon which is readily decomposed at the carburizing temperature.
- A mixture consisting of 5-15% methane (or propane) in a neutral carrier gas is used. The methane decomposes according to the following reaction:

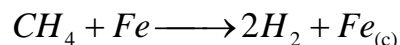

- The carbon potential of the gas mixture increases with increasing concentration of methane. Too large a concentration or too high a gas velocity releases carbon faster than it can be absorbed and may result in soot formation on the surface.
- Closer control of temperature and case depth is possible in gas carburizing, as compared to pack carburizing. Also, post quenching can be done directly.

Heat treatment after carburizing

- Since steel is carburized in the austenite region, direct quenching from the carburizing temperature will harden both the case and core will harden both the case and core if the cooling rate is greater than the critical cooling rate. Direct quenching of coarse grained steels often leads to brittleness and distortion, so that this treatment should be applied only to fine grained steels. A *diagrammatic representation of various hardening treatments for carburized steels shown in next slide.*

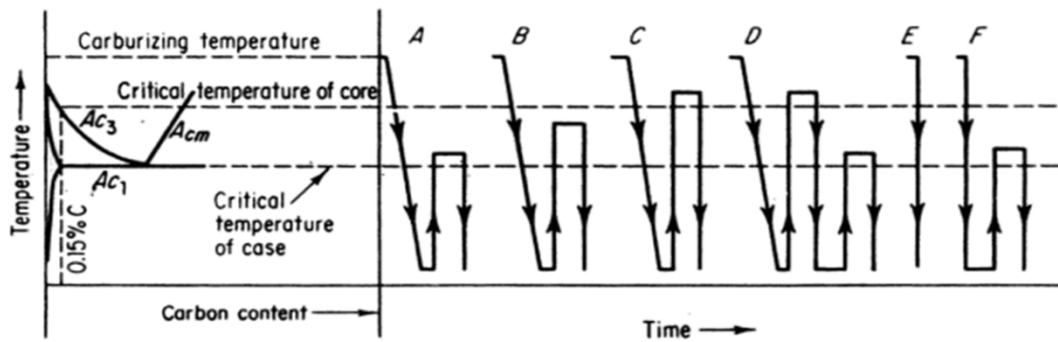

TREATMENT	CASE	CORE
A – best adapted to fine grained steels	Refined; Excess carbide not dissolved	Unrefined; soft and machinable
B-best adapted to fine grained steels	Slightly coarsened; some solution of excess carbide	Partially refined; stronger and tougher than A
C-best adapted to fine grained steels	Somewhat coarsened; solution of excess carbide favored; austenite retention promoted in highly alloyed steels.	Refined: maximum core strength and hardness; better combination of strength and ductility than B
D-best treatment for coarse grained steels	Refined solution of excess carbide favored; austenite retention minimized	Refined; soft and machinable; maximum toughness and resistance to impact
E-adapted to fine grained steels only	Unrefined with excess carbide dissolved; austenite retained; distortion minimized	Unrefined but hardened
F-adapted to fine grained steels only	Refined; solution of excess carbide favored; austenite retention minimized	Unrefined; fair toughness

Cyaniding and Carbonitriding

- In this case that contain both carbon and nitrogen are produced in liquid salt baths (cyaniding) or by use of gas atmospheres (carbonitriding). The temperatures used are generally lower than those used in carburizing, being between 750-900°C.
- Exposure is for a shorter time, and thinner cases are produced, up to 0.010in. For cyaniding and up to 0.030in. For carbonitriding.
- In Cyaniding is done in a liquid bath of NaCN, with the concentration varying between 30 and 97%. Both carbon and nitrogen enter the steel via the following reactions:

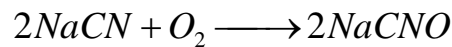

- The temperature used for cyaniding is lower than that for carburizing and in the range of 800-870°C. the time of cyaniding is 0.5-3 hour to produce a case depth of 0.25 mm or less.
- Carbonitriding is a case-hardening process in which a steel is heated in a gaseous atmosphere of such composition that carbon and nitrogen are absorbed simultaneously.
- This process is also known as dry cyaniding or gas cyaniding. It is the gas carburizing process modified by the addition of anhydrous ammonia.
- The decomposition of ammonia provides the nitrogen, which enters the steel along with carbon.
- A typical gas mixture consists of 15% NH₃, CH₄, and 80% of neutral carrier gas. The temperature used is 750-900°C. With increasing temperature, a greater proportion of carbon enters the steel.
- The presence of nitrogen in the austenite accounts for the major differences between carbonitriding and carburizing. Carbon-nitrogen austenite is stable at lower temperatures than plain-carbon austenite and transforms more slowly on cooling. Carbonitriding therefore can be carried out at lower temperatures and permits slower cooling rates than carburizing in the hardening operation.

Nitriding

- In contrast to the processes described before, nitriding is carried out in the ferrite region. Consequently, no phase change occurs after nitriding .
- This part to be nitrided should possess the required core properties prior to nitriding. Pure ammonia decomposes to yield nitrogen which enters the steel:
- The solubility of nitrogen $2NH_3 \longrightarrow 2N + 3H_2$ of the nitrogen that enters the steel forms hard nitrides (e.g. Fe₃N). A typical nitriding steel contains alloying elements of 1%Al, 1.5%Cr and 0.2%Mo. Al, Cr, and Mo form very hard and wear resistant nitrides.

- The temperature of nitriding is 500-590°C. the time for a case depth of 0.02mm is about 2 hour. In addition with wear resistance, it also increases the resistance of a carbon steel to corrosion in moist atmospheres.
- A common problem encountered in nitriding is the formation of γ nitride (Fe_4N) on the outer layers of the case , known as the “white layer”, as it looks white under the microscope. This layer is very brittle and tends to crack. It must be removed by final grinding operation. Its formation can be minimized by maintaining the correct ratio of NH_3/ H_2 in the gas mixture during the heat treatment.

Thermal Energy Treatments

- For large work pieces, such as large gears and complicated in such cases, flame hardening means of an oxyacetylene should be done rapidly by the surface quenched, before heat transfer to the core occurs.

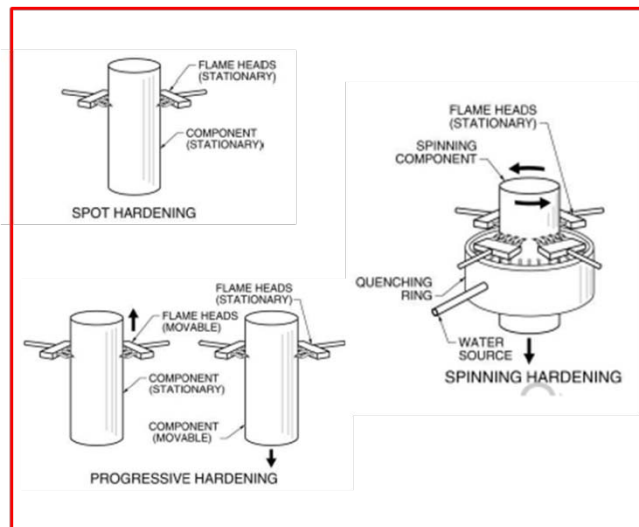

mill rolls, cross sections, is done by torch. Heating torch and the appreciable

- Four methods are generally use for Flame Hardening
 - Stationary (Spot): Torch and work is stationary
 - Progressive: Torch moves over a work piece
 - Spinning: Torch is stationary while work piece rotates
 - Progressive-spinning: Torch moves over a rotating work piece.

Induction Hardening

- Here, an alternating current of high frequency passes through an induction coil enclosing the steel part to be heat treated. The induced emf heats the steel. the depth up to which the heat penetrates and rises the temperature above A_{c3} is inversely proportional to the square root of the AC frequency.
- Correspondingly, the hardened depth decreases with increasing frequency in induction hardening, the heating time is usually a few seconds. Immediately after heating water jets are activated to quench the surface . Martensite is produced at the surface, making it hard and wear resistant. The microstructure of the core remains unaltered. Induction hardening is suitable for mass production of articles of uniform cross section

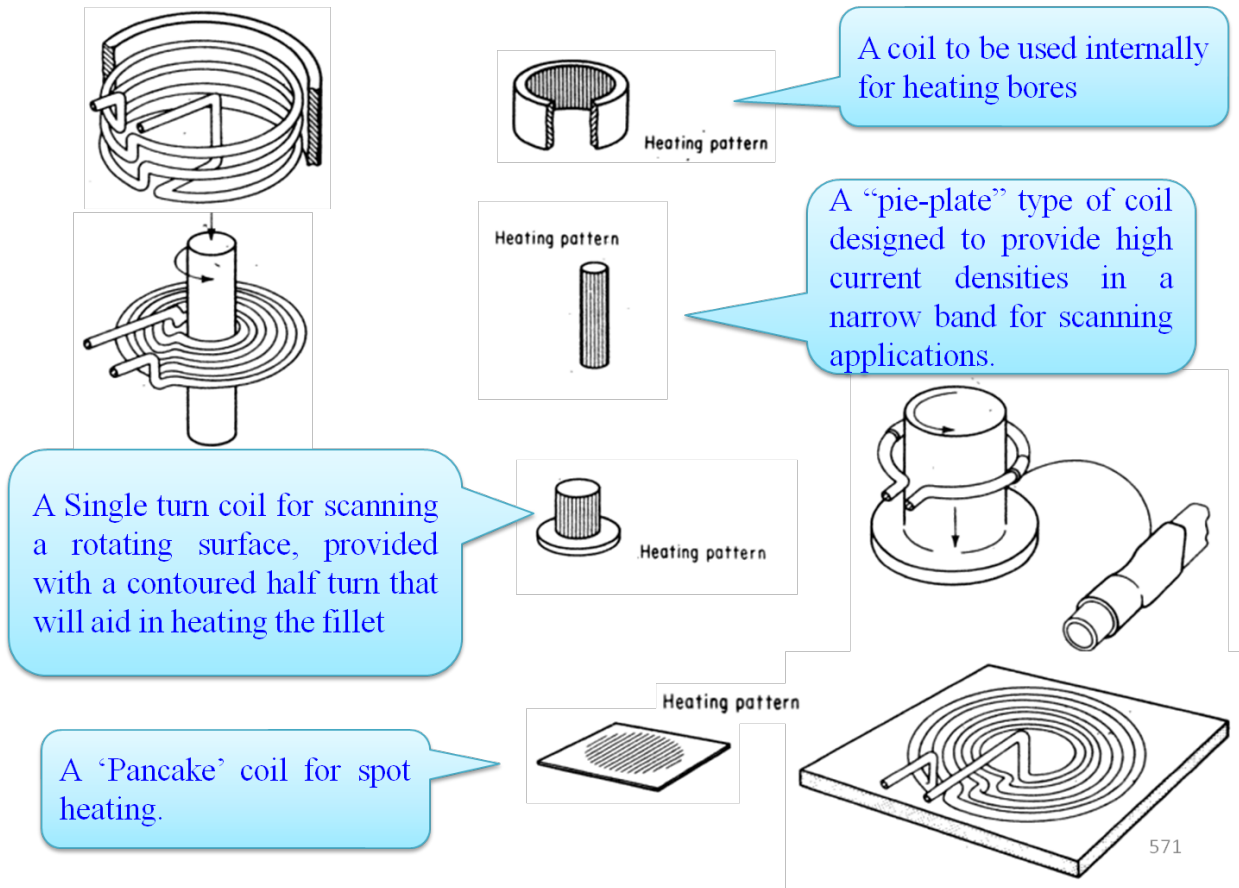

Laser Hardening

- Laser hardening treatment is widely used to harden localized areas of steel and cast iron machine components. This process is sometimes referred to as laser transformation hardening to differentiate it from laser surface melting phenomena.
- There is no chemistry change produced by laser transformation hardening, and the process, like induction and flame hardening, provides an effective technique to harden ferrous materials selectively.
- As laser beams are of high intensity, a lens is used to reduce the intensity by producing a defocused spot of size ranging from 0.5 to 25 mm. proper control of energy input is necessary to avoid melting.
- Laser transformation hardening produces thin surface zones that are heated and cooled very rapidly, resulting in very fine Martensitic microstructures, even in steels with relatively low hardenability. High hardness and good wear resistance with less distortion result from this process.
- Laser hardening has the advantage of precise control over the area to be hardened, an ability to harden reentrant surfaces, very high speed of hardening and no separate quenching step (the quench is effected by the mass of the unheated material).
- The disadvantage is that the hardening is shallower than in induction and flame hardening.

Electron Beam (EB) Hardening

- Electron Beam (EB) hardening is like laser treatment, is used to harden the surfaces of steels. The EB heat treating process uses a concentrated beam of high-velocity electrons as an energy source to heat selected surface areas of ferrous parts. Electrons are accelerated and are formed into a directed beam by an EB gun.
- After exiting the gun, the beam passes through a focus coil, which precisely controls beam density levels (spot size) at the work piece surface and then passes through a deflection coil.
- To produce an electron beam, a high vacuum of 10^{-5} torr is needed in the region where the electrons are emitted and accelerated. This vacuum environment protects the emitter from oxidizing and avoids scattering of the electrons while they are still traveling at a relatively low velocity.
- Like laser beam hardening, the EB process eliminates the need for quenchants but requires a sufficient work piece mass to permit self quenching.
- A mass of up to eight times that of the volume to be EB hardened is required around and beneath the heated surfaces. Electron beam hardening does not require energy absorbing coatings, as does laser beam hardening.

Stainless Steels

- Stainless Steels are a large group of special alloys developed primarily to withstand corrosion. These steels contain chromium in excess of 12% by weight which imparts “stainless” characteristics to iron alloys.

AISI Grades of stainless steels:

Series Designation	Groups
2XX	Chromium-Nickel-Manganese; Nonhardenable, Austenitic, Nonmagnetic
3XX	Chromium-Nickel; Nonhardenable, Austenitic, Nonmagnetic
4XX	Chromium; Hardenable, Martensitic, Magnetic
4XX	Chromium; Nonhardenable, Ferritic, Magnetic
5XX	Chromium; Low chromium; Heat-Resisting

Martensitic Stainless Steel

- These are primarily straight chromium steels with 11.5 to 18% Cr, 0.15% C, 1.25% Mn, and 1% Si.
- Common examples are 403, 410, 416, 420, 440A, 501 & 502 (AISI grades).
- Used for turbine blades and corrosion resistant applications.

Heat Treatment

- Process Annealing → 650 - 760 ° C, increase ductility and machinability
- Austenitizing → 925 -1065 ° C followed by oil quenching or air cooling, increase corrosion resistance and strength

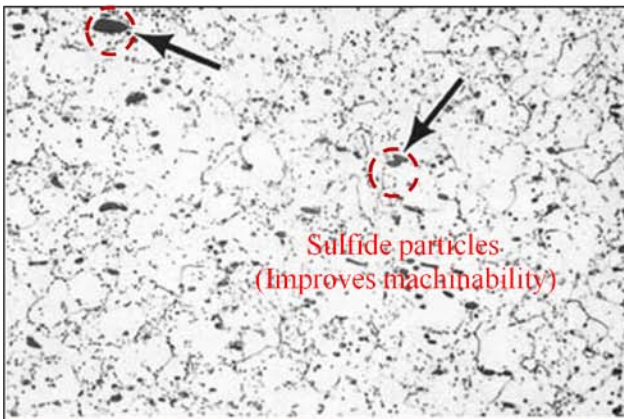

Microstructure of annealed 416 stainless steel etched with Vilella's reagent

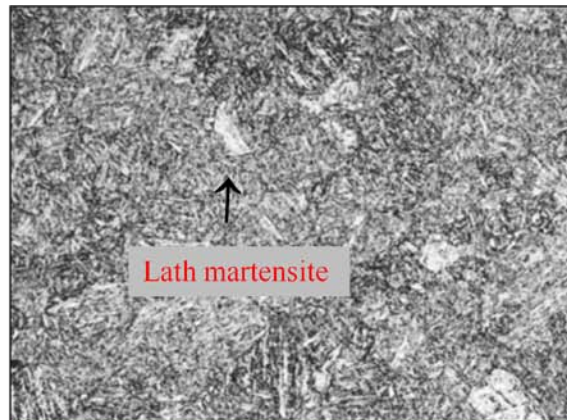

Microstructure of hardened type 403 stainless steel etched with 4% picral-HCl

Austenitic Stainless Steel

- These are chrome-nickel (3xx type) or chrome -nickel- manganese(2xx type) alloys.
- Total content of Ni and Cr is at least 23%.
- Difficult to machine but can be improved by addition of selenium or sulfur.
- Best high temperature strength and scaling resistance. Hence shows best corrosion resistance
- Used in chemical industry and for household and sanitary fittings.

Heat Treatment

- Cold working causes work hardening but hot working can easily be done.
- Annealing at high temperatures → Recrystallization and carbide solution
- Solution treatment → Dissolution of chromium carbides

Tool Steel

- Tool steel refers to a variety of carbon and alloy steels that are particularly well-suited to be made into tools.
- Characteristics include high hardness, resistance to abrasion (excellent wear), an ability to hold a cutting edge, resistance to deformation at elevated temperatures (red-hardness).
- Tool steel are generally used in a heat-treated state.

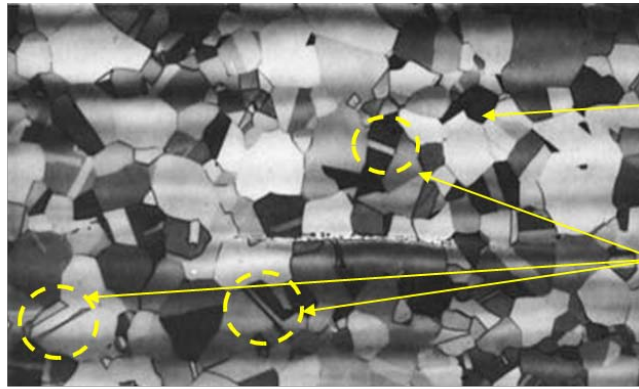

Equiaxed grains

Annealing twins

Microstructure of annealed type 316L austenitic stainless steel etched in 20% HCl, 2% NH₄FHF, 0.8% PMP

Ferritic Stainless Steel

- These are primarily straight chromium steels with 14 to 27% Cr. Carbon is restricted both to maintain high toughness and ductility and to prevent austenite formation (As carbon expands the gamma loop)
- These steels can be cold formed easily and hence are used for deep drawn parts such as vessels for food and chemical industries and for architectural and automotive trim.

Heat Treatment

- Can be cold or hot worked.
- Annealing → 760 - 966°C, Recrystallization of cold-worked structures → achieves maximum softness, ductility and corrosion resistance.

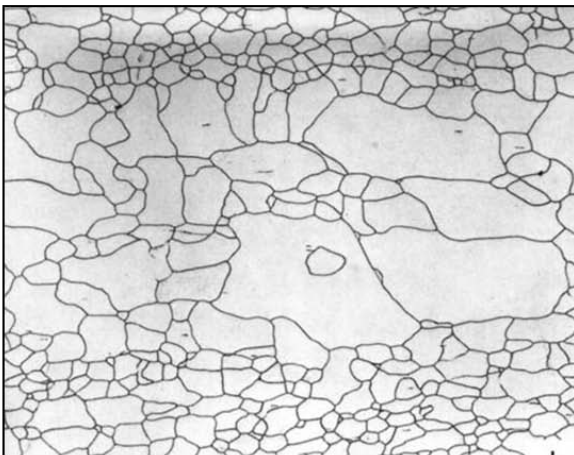

Single-phase microstructure of an annealed ferritic stainless steel

Microstructure of annealed ferritic stainless steel containing 26% Cr and 1% Mo, etched electrolytically in 60% HNO₃-H₂O

AISI-SAE tool steel grades		
Defining property	AISI-SAE grade	Significant characteristics
Water-hardening	W	
Cold-working	O	Oil-hardening
	A	Air-hardening; medium alloy
	D	High carbon; high chromium
Shock resisting	S	
High speed	T	Tungsten base
	M	Molybdenum base
Hot-working	H	H1-H19: chromium base H20-H39: tungsten base H40-H59: molybdenum base
Plastic mold	P	
Special purpose	L	Low alloy
	F	Carbon tungsten

Uses

- Shock resisting tool steels → Intended for applications requiring toughness and resistance to shock - loading such as hammers, chisels, punches, driver bits and others.
- Water hardening tool steels → Shallow hardened and relatively low resistance to softening. They are suitable for woodworking tools, hand-metal cutting tools such as taps and reamers and cutlery.
- Steels for Room Temperature Use (Classified according to their quenching media)
- Water hardened grades (W) → Plain carbon steels with 0.6-1.0 %C. These have a low hardenability, i.e., martensite only to a depth of 0.5 in. V can be added (forms V_4C_3) to improve the hardness and wear resistance of these steels.
- Shock resistant grades (S) → Contain small amounts of Cr or Mo and are quenched in oil. They have lower C contents (0.5%) to improve impact strength.
- Oil hardened grades (O) → Small percentages of Cr and W with 0.9 %C. They have medium hardness and are used to short run cold forming dies.
- Air hardening grades (A) → Greater amounts of Cr and Mo and 1 %C. Used for complicated shapes and thread rolling. Mo and W are relatively expensive so they are only added in small amounts to give much improved hardenability.
- High carbon, high Cr grades (D grade) → 12 %Cr and 1.5 -2.25 %C are extremely wear resistant and used for long run dies and for gauges. Chromium is a relatively low cost addition for increasing hardenability with the excess Cr, $Cr_{23}C_6$ is also formed, which improves wear resistance.

Steels for High Temperature Use

- Chromium hot working steels (H grades)→ 5 -7 % Cr, 0.4-1.0% V, 1.5-7.0% W, 1.5% Mo, 0.35% C. Medium hot working for Mg and Al extrusion die-casting dies.
- Tungsten hot working steels (H)→ 9.5 -12 % W, 3.5-12.0 % Cr, 0.35 % C. Hot working, extrusion and forging dies for brass, nickel and steel.
- Tungsten high speed steel (T)→ 12 -18 % W, 4.0 % Cr, 1-5 % V, 0.7-1.5 % C. Original high speed (HS) cutting steel with excellent HT wear resistance.
- Molybdenum HS steel (M) → 3.5-8.0 % Mo, 1.5-6.0 % W, 4.0 % Cr, 1-5 % V, 5 % Co, 0.8-1.5 % C. Used for 85% of US cutting steels before the advent of ceramic cutting tools.

High Speed Steel (HSS)

- HSS is a subset of tool steel, commonly used in tool bits and cutting tools. It is often used in power saw blades and drill bits.
- They are characterized by high carbon contents, sometimes up to 1.5%, and major additions of strong carbide forming elements such as chromium, molybdenum, tungsten and vanadium. Up to 12% Co is also included in some of the more complex grades.
- It can withstand higher temperatures without losing its temper (hardness) which allows it to cut faster than high carbon steel, hence the name.
- Other characteristics include high hardness, resistance to abrasion (excellent wear), an ability to hold a cutting edge, resistance to deformation at elevated temperatures (red-hardness).
- Modulus Of elasticity: 221GPa, Density : 8767 kg/m³ (↑ durability & hardness), Thermal Conductivity: 21W/m/K
- HSS are mainly of two types: Tungsten based ones (T grades), Molybdenum based ones (M grades)

Three popular grades of high-speed steel

<i>AISI-SAE grade</i>	<i>C%</i>	<i>W%</i>	<i>Mo%</i>	<i>Cr%</i>	<i>V%</i>
T1	0.75	18		4	1
M1	0.8	2	8	4	1
M2	0.85	6	5	4	2

- Martensite morphology
- Arthur C. Reardon, Metallurgy for the Non-Metallurgist, ASM, Second Edition, 2011.
- H. K. D. H. Bhadeshia and R. W. K. Honeycombe, Steels: Microstructure and Properties, Elsevier, Third Edition, 2006.

3. George Krauss, Steels: Processing, Structure and Performance, ASM, First Edition, 2005